

MASTERMIND GT™

User's Manual



RJM MUSIC TECHNOLOGY, INC.

MASTERMIND GT™

User's Manual

Version 4.1
9/11/2018

RJM Music Technology, Inc.
2525 Pioneer Ave.
Suite 1
Vista, CA 92081
+1-760-597-9450
email: support@rjmmusic.com
web: www.rjmmusic.com

Copyright © 2012-2018 RJM Music Technology, Inc. All Rights Reserved

RJM and the RJM logo are registered trademarks of RJM Music Technology, Inc. RG-16, Amp Gizmo, Effect Gizmo, Rack Gizmo, Switch Gizmo, Mastermind and Mastermind GT are trademarks of RJM Music Technology, Inc. All other trademarks are the property of their respective holders.

Table of Contents

Table of Contents	v
Introduction.....	1
Front Panel.....	2
Front Panel Controls.....	2
Rear Panel	3
Rear Panel Connections (left side).....	3
Rear Panel Connections (right side).....	4
Basic Operation	6
Presets and Banks	7
Instant Access Buttons.....	7
Button Pages.....	8
IA Store	8
IA Mode.....	8
Initial Setup - Adding a Device.....	9
Reading Preset Names	11
Reading Preset Names with Scenes	12
Using the Create Songs Option.....	13
Setup with a Fractal Audio Axe-Fx I or II.....	14
Connections.....	14
Settings.....	14
Usage	15
Tuner.....	15
Tempo	15
Troubleshooting	15
Slave Mode.....	15
Selecting Slave Mode.....	16
Setup with a Fractal Audio Axe-Fx III	17
Connections.....	17
Settings.....	17
Expression Pedal Setup	18
Usage	18
IA Mode	19
Tuner.....	19
Tempo	19
Troubleshooting	19
Technical Details.....	19
CC Values.....	19
Get Preset Names with Scenes.....	20
Get Preset Names with Scenes and Create Songs.....	20
Setup with a Kemper Profiling Amp	21
Connections.....	21
Settings.....	21
Usage	22
Tuner.....	22
Tempo	22

Troubleshooting	22
Slave Mode.....	22
Selecting Slave Mode	23
Setup with RJM Music Products.....	24
Connections	24
Important Notes on Phantom Power!.....	24
Chaining Multiple Devices	24
Setup	24
Editing Buttons.....	25
Swap Buttons.....	25
Copy Button.....	25
A Special Note on Preset Buttons.....	25
Assign Buttons	26
Low Level Editing.....	27
Hold Buttons.....	28
Cycle Buttons.....	29
Cycle Menu	30
Editing Presets.....	31
Name.....	32
Button Page	32
Alt Preset.....	32
Tempo.....	32
MIDI Clock Div / Auto Tap Div	32
Btn Color	32
Expression Pedals and External Switches	32
Local Button Page	32
Preset Actions.....	33
Edit Scenes	33
IA Button State.....	33
PC Messages.....	33
Song and Setlist Mode.....	35
Editing Songs.....	35
Editing Setlists.....	36
Using a Setlist.....	37
Expression Pedals	39
The Mission Engineering SP1-RJM	39
Expression Pedal Setup	39
Setting Up The Expression Pedal Position Switch.....	40
External Switches	43
Remote Mode	44
External MIDI Control.....	45
Setlist=None.....	45
Setlist active, Bank=Song On	45
Setlist active, Bank=Song Off.....	45
CC Link: Controlling buttons using incoming CC messages	45
Remote Control	46
Other Special Features.....	47

Global Preset.....	47
Page, Preset, Scene, Song and Setlist Menus.....	47
Preset Number Selection.....	47
IA Linking.....	47
Tap Tempo and MIDI Clock.....	47
Auto Tap.....	48
Macros.....	48
Loading and Saving Settings to a USB Flash Drive.....	49
Load Settings.....	49
Save Settings.....	49
Formatting.....	50
Connecting to a Computer.....	51
Mastermind GT Editor.....	51
Upgrading Firmware.....	52
Setup Mode Reference.....	53
Button Selection.....	53
Text Entry (Mastermind GT/10 and Mastermind GT/16).....	54
Number Entry (Mastermind GT/10 and Mastermind GT/16).....	55
Text and Number Entry (Mastermind GT/22).....	55
Special Characters.....	56
Special Values.....	56
Main Menu.....	57
Display Settings Menu.....	59
System Functions Menu.....	59
Edit Devices.....	60
Edit Device Menu.....	60
Assign Buttons.....	62
Edit Buttons.....	62
Action Edit.....	65
CC Toggle or CC Momentary.....	65
PC (Program Change).....	65
Note.....	66
Sysex.....	66
System.....	66
BPM.....	66
Exp Pedal.....	66
IA Mode.....	66
IA Store.....	66
Macro.....	66
Page.....	67
Preset.....	67
Setlist.....	67
Song.....	67
Step.....	67
Tuner.....	67
Edit Pages.....	67
Edit Presets.....	68
Expression Pedals.....	69
Edit Groups.....	70

MIDI Settings Menu.....	70
Sysex Messages Menu.....	71
Edit Macros Menu.....	71
Specifications.....	72
XLR MIDI Connectors (Mastermind GT/22 only).....	72
Mastermind GT MIDI Implementation Chart.....	74

Introduction

Thank you for purchasing the Mastermind GT MIDI foot controller! The Mastermind GT is the most technologically advanced MIDI controller available and has been designed to be able to control the most complex MIDI systems, but is also incredibly easy to use.

The Mastermind GT includes many features that set it apart from the competition:

- 10, 16 or 22 buttons, each with a graphic LCD display over it
- The display over each button can be customized with different text labels and backlighting colors
- Large main LCD display that displays preset, song, and other status information
- Any button on the controller can be assigned to any function
- There can be up to 16 global button pages, each of which can be configured with its own full set of buttons
- Enough storage for 768 presets and 16 connected devices
- Each preset can also have its own local button page
- Each instant access button can send 20 additional MIDI messages
- Each preset can change the state of every instant access button on all 16 button pages
- Each preset can send program and bank changes to each device, plus also send up to 10 general MIDI messages
- "IA Mode" converts up to 21 (15 on the Mastermind GT/16, 9 on the Mastermind GT/10) of the available buttons to Instant Access buttons with the tap of a single button
- 4 Expression pedal inputs
- 2 External switch inputs, both of which can accept a 1 button or 2 button switch.
- USB "A" port allows the use of a USB flash drive for settings backup and firmware upgrades
- USB "B" port for connection to a PC
- Phantom power capability when using a 7 pin MIDI cable or 6-pin XLR cable
- Two 9VDC outputs for powering tuners or pedals
- Remote In jack, which allows the synchronized use of multiple Mastermind GT controllers on stage

Front Panel

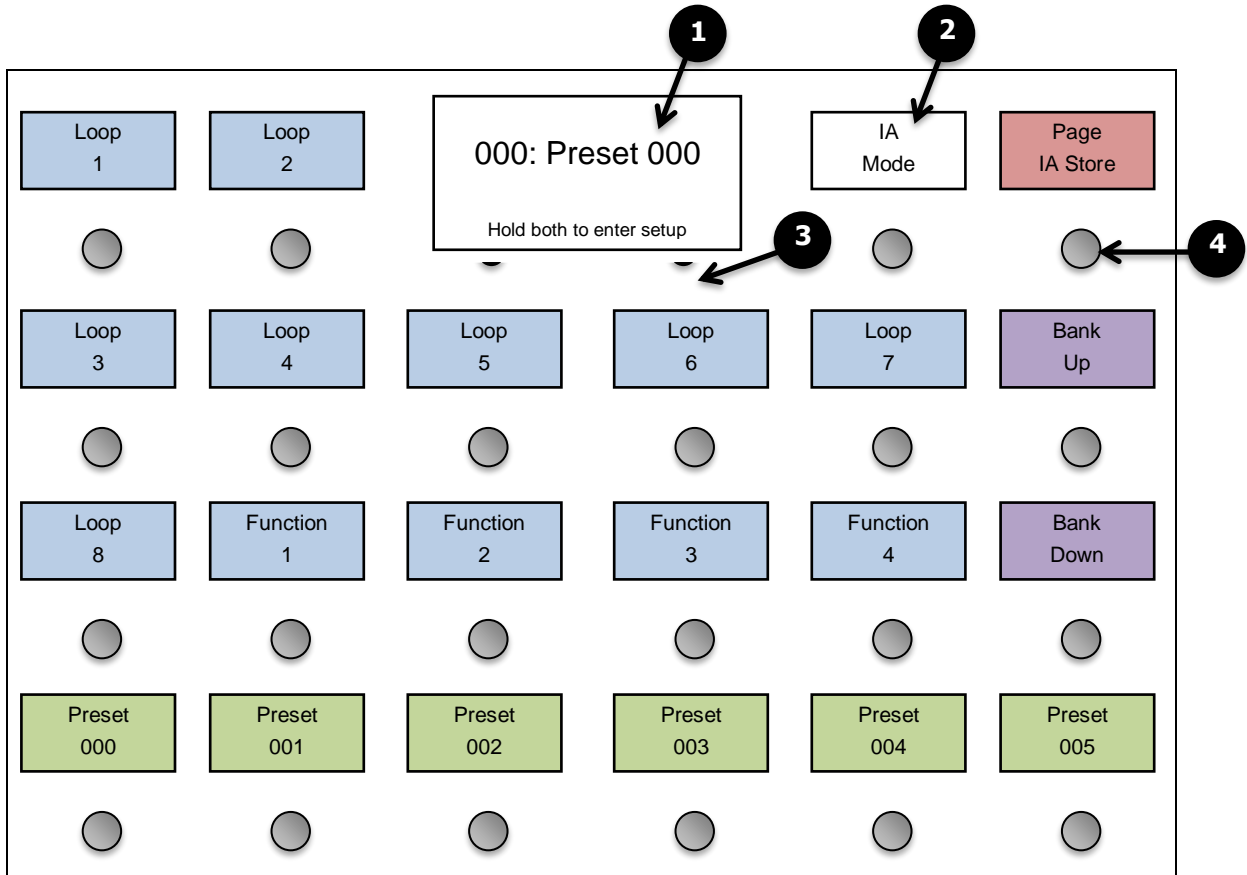

Front Panel Controls

1. Main Display – This is the main status display that shows the current preset and/or song name, preset number and other status information. The display format is user configurable, with several options.

2. Button Display – These 22 displays (16 displays on the Mastermind GT/16, 10 displays on the Mastermind GT/10) are present over every button. They indicate the current function the button performs and the status of the button. These displays have RGB color backlights and can be configured for different functions and background colors.

3. Soft Buttons – These two small buttons are used only in Setup Mode. To enter Setup Mode, hold both of these buttons for approximately 2 seconds, until the Setup Mode screen is visible. The status bar at the bottom of the main display indicates the current function of these buttons.

4. Footswitches – These 22 footswitches (16 footswitches on the Mastermind GT/16, 10 footswitches on the Mastermind GT/10) are used in both Setup Mode and normal operation. The current function of each footswitch is indicated by the display above it.

Rear Panel

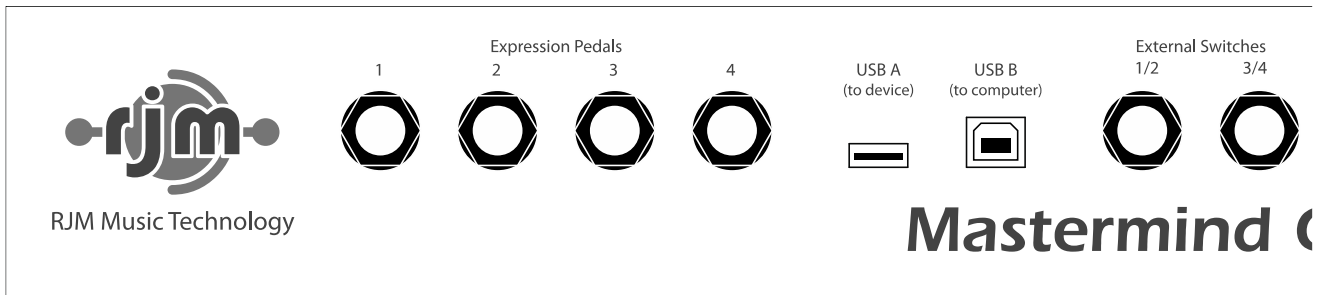

Rear Panel Connections (left side)

Expression Pedals 1-4 – Up to four expression pedals can be connected to these ports using ¼” TRS cables. Refer to the [Expression Pedals](#) section for more details.

USB A – This is a USB port designed for use with a USB flash drive. A flash drive can be used to back up or transfer settings, and is also used for firmware upgrades.

USB B – This USB port is designed to connect to a PC or Mac. When connected, the Mastermind GT will appear as a MIDI interface connected to the computer.

External Switches 1/2 and 3/4 – External footswitches can be connected to these ports to add four more switches to the system. Each port can take a single or double footswitch connected with a ¼” TRS (tip-ring-sleeve) cable. These switches are fully configurable and can perform all of the operations the on-board switches can. More details on these switches can be found in the [External Switches](#) section.

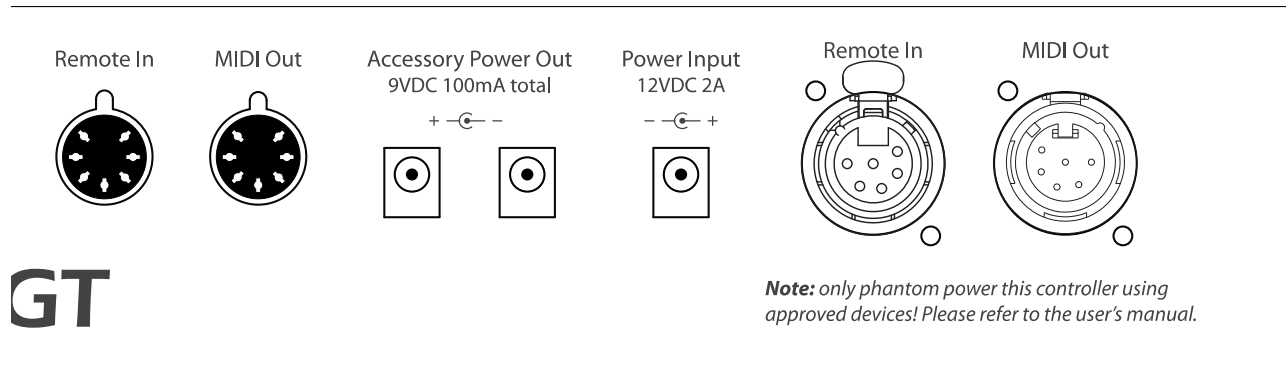

Rear Panel Connections (right side)

Remote In – This is a MIDI input port. It can be used for receiving MIDI patch data, program changes or can be used to connect multiple Mastermind GTs together and allow them to control each other. This is a 7-pin MIDI port, but you can always use a standard 5-pin MIDI cable to connect to this port.

MIDI Out – This is the main MIDI output. Connect this port to the MIDI device(s) you wish to control. You can use a standard 5-pin MIDI cable here, but if you connect a 7-pin MIDI cable, you can phantom power the Mastermind GT over the MIDI cable. If you phantom power, you can use the Mastermind GT without it needing its own power supply. Please refer to the note below for more details.

Accessory Power Out – These two power output ports provide 9VDC center negative power for powering tuners, wah pedals and the like. The outputs can deliver 100mA total. This is enough to power a typical wah pedal and any of the popular pedalboard tuners.

Power Inputs – This is the main power input for the Mastermind GT. The Mastermind GT requires a 12VDC supply with at least 2A of current capacity. **NOTE:** Do not connect power to this jack if you are phantom powering the Mastermind GT!

Remote In (XLR) – (*Mastermind GT/22 only*) This is a second MIDI input port that works the same way as the other Remote In. This one has a 6-pin female XLR connector designed to connect to another Mastermind GT. *Do not use the XLR and the standard DIN MIDI inputs at the same time!* Doing so can cause unpredictable results.

MIDI Out (XLR) – (*Mastermind GT/22 only*) This is a second MIDI output port that is wired in parallel with the other MIDI Out port. This one has a 6-pin male XLR connector designed to connect to RJM Music products such as the Effect Gizmo and Rack Gizmo, or another Mastermind GT. *Do not use the XLR and the standard DIN MIDI outputs at the same time!* Doing so can cause unpredictable results. This jack also accepts phantom power from a compatible device.

IMPORTANT NOTES ON PHANTOM POWER: Don't connect a power supply to the Mastermind GT if you are phantom powering it! Doing so can damage the Mastermind GT and/or connected devices! Also, before attempting to phantom power the Mastermind GT, please make sure the device you're connecting to is

compatible. The device must provide 12 volts DC or 9 volts AC over pins 6 and 7 of the MIDI cable (or pins 1 and 2 of the 6-pin XLR connector), and must be able to handle the current draw of the Mastermind GT.

Basic Operation

Right out of the box, the Mastermind GT is configured like a standard MIDI controller. The preset buttons are green and instant access buttons are blue. Buttons with other functions are indicated by color and text label. The Mastermind GT is configured to control a single Rack Gizmo (our flagship audio loop switcher / function switcher), and to send program change messages on MIDI channel 1.

Mastermind GT/10 default button configuration

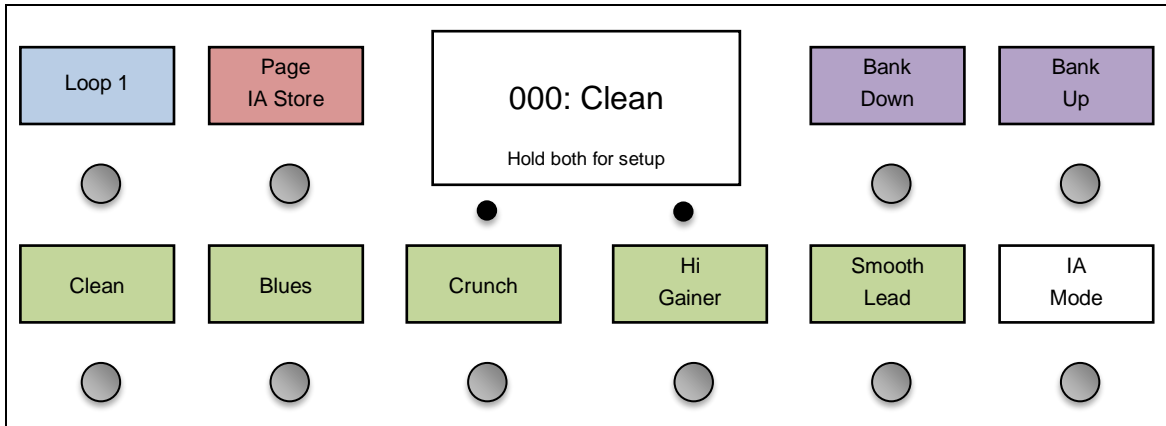

Mastermind GT/16 default button configuration

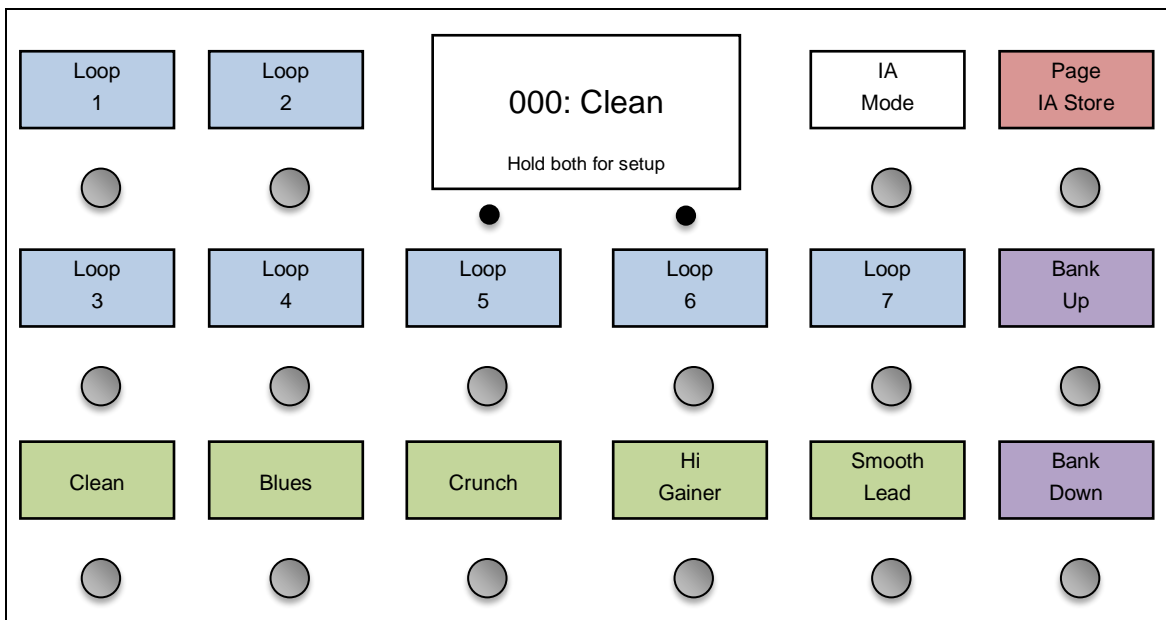

Mastermind GT/22 default button configuration

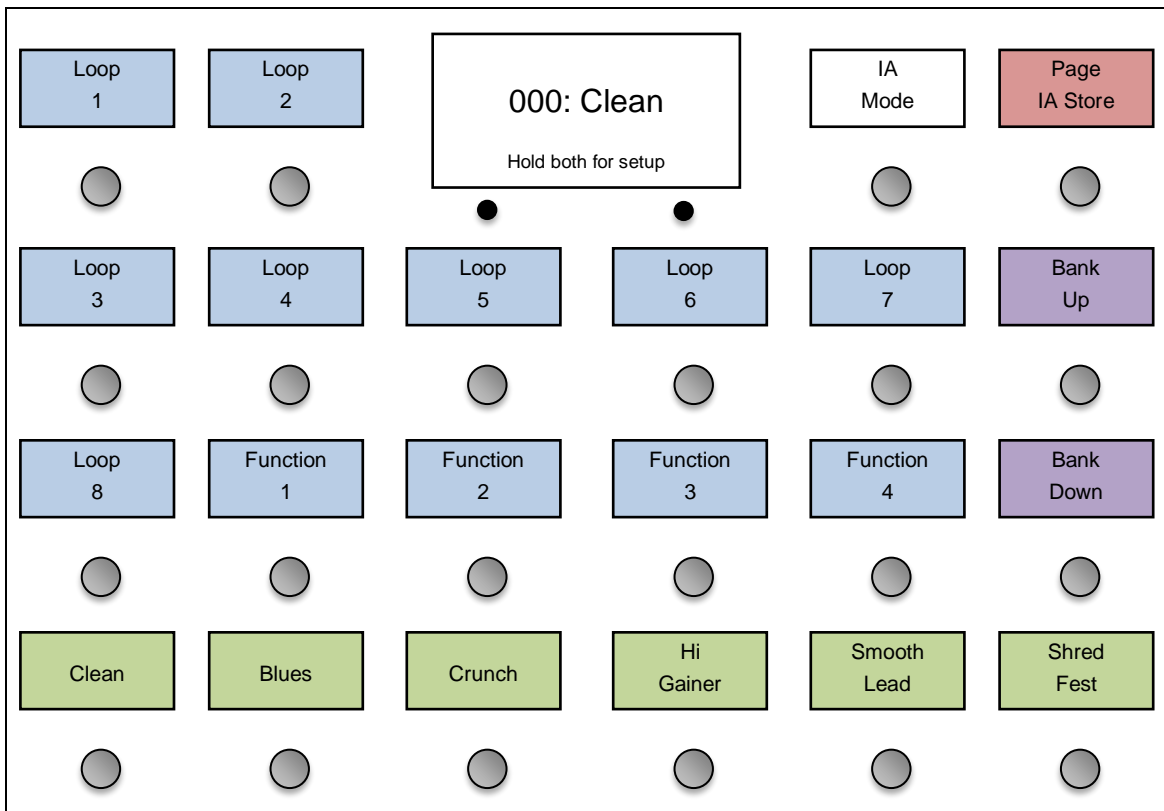

Presets and Banks

The green buttons are preset selection buttons. These are typically used to send program change messages to effects processors and to turn on or off multiple loops on audio switchers. Each preset can simultaneously affect every device in your system, so presets are typically used for different songs, different song sections or any time you need to define a specific sound.

The Mastermind GT can store up to 768 presets. They are arranged in banks, and each bank is defined by how many preset buttons are available. The default configuration is to have 6 preset buttons, so a bank will contain 6 presets. On the Mastermind GT/16 and GT/10, there are 5 preset buttons by default and a bank has 5 presets. The Bank Up and Bank Down will shift up or down one bank, respectively.

When you press the Bank Up or Down button, the text over the preset buttons will change to show the presets in the selected bank. The preset buttons will flash, indicating that you need to select a preset. You can either continue to use the Bank Up and Down buttons to find the bank you need, or you can press one of the preset buttons to select that preset. The Mastermind GT will not switch to a new preset – and will not send any MIDI messages – until you leave the bank selection mode by selecting a preset.

Instant Access Buttons

The blue buttons on the controller are the instant access buttons. Unlike the preset buttons, which affect everything in your system simultaneously, an instant access button typically controls one particular feature or effect in your system. You might assign an instant access button to switch on a fuzz pedal connected to a loop switcher, or to turn on a chorus effect block in an effect processor. You can think of your instant access buttons as a virtual pedalboard – one button press turns on or off one effect.

By default, the Instant Access buttons are set up to control a Rack Gizmo, but they can be programmed to control pretty much any MIDI device, even more than one device at a time. Please refer to the Editing Buttons section for information on how this is done.

Button Pages

The **Page / IA Store** button allows you to switch between multiple pages of buttons. Each page can have a completely different button configuration – you can change which instant access buttons are shown, how many preset and instant access buttons there are and where those buttons are located.

Pressing the **Page / IA Store** button switches from one button page to the next. Once the last page is reached, pressing the **Page / IA Store** button switches back to the first page. There can be up to 16 pages of buttons, but you can limit the number of pages visible to avoid having to scroll through pages you don't use. By default, two button pages are available, but this can always be changed in Setup Mode.

Each preset in the Mastermind GT can also have its own "local" button page. This page takes the place of button page 16 when the preset is loaded. The local button page will be shown by default, but you can always access the other button pages using the **Page / IA Store** button.

IA Store

The other function of the **Page / IA Store** button is to store information to the current preset. If you hold the **Page / IA Store** button for three seconds, the preset's current state is stored to memory. This state includes the following:

- The on/off state of any IA buttons
- The state of any IA Cycle buttons
- The currently selected button page
- The current bank and PC number for each device (adjusted using the Device PC +/- buttons)

This allows you to use the GT's buttons to choose your IA button states, button page and device PCs and store them to each preset without having to enter the GT's setup mode.

IA Mode

The **IA Mode** button allows you to convert every button (except the **IA Mode** button itself) to an instant access button. This function is also known as "IA reveal" on other MIDI controllers. In this mode, you can have up to 21 instant access buttons available (15 IA buttons on the Mastermind GT/16, 9 IA buttons on the Mastermind GT/10). This allows you to switch presets to perform the more dramatic sound changes (perhaps from song to song), then tap the **IA Mode** button which allows you to fine tune by turning individual effects on and off. You can decide if all of the buttons switch to instant access, or if some retain their functions in instant access mode.

Initial Setup - Adding a Device

The first thing you'll probably need to do with the Mastermind GT is to add a device. This informs the GT about what it's connected to and what it needs to do to control that device. The Mastermind GT has an internal database of information about popular MIDI devices, so often times you might only need to select the device from a list and the Mastermind GT will do the rest of the setup for you.

To add a device, first enter Setup Mode by holding the two soft buttons under the main display:

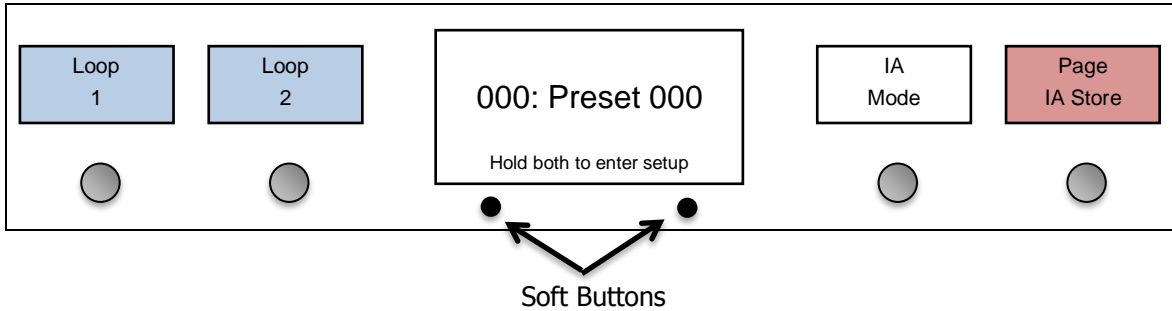

Next, select the **Edit Devices** option:

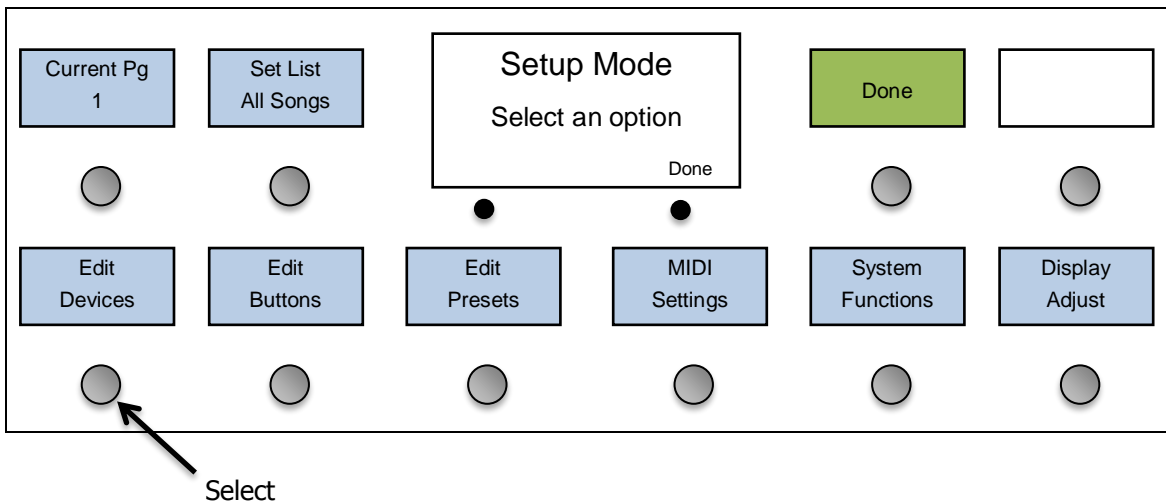

You will see a list of devices defined in your system. By default, a single Rack Gizmo is defined. You can select the Rack Gizmo if you want to replace that device with another, or you can select another empty device slot to add a second device of another kind.

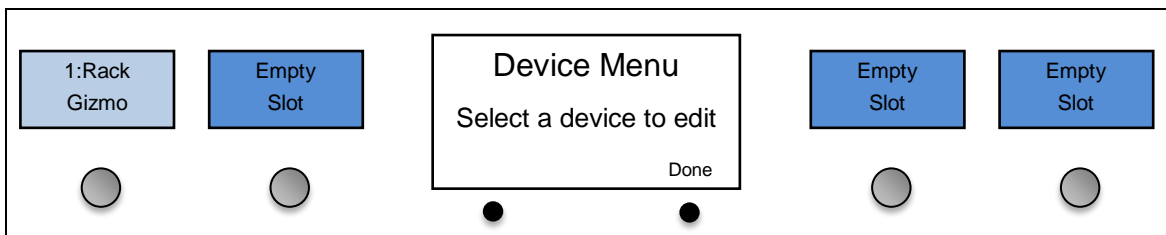

Once a device slot is selected, you are taken to the Device Edit screen. Select the **Type** button in the upper left hand corner to set the type of this device.

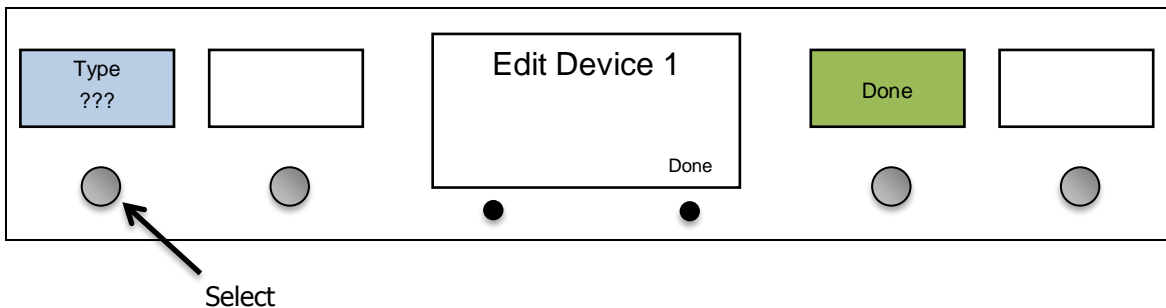

You will be presented with a list of device manufacturers. Select your manufacturer from the list, then select the model of the device in the next list that is presented.

Manufacturers (this is just an example, the list you see will be different):

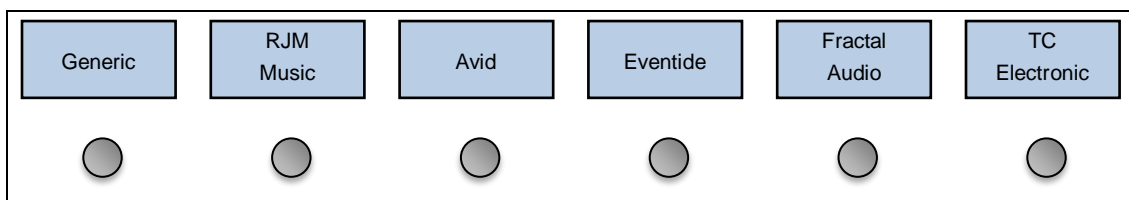

Device models (again, just an example):

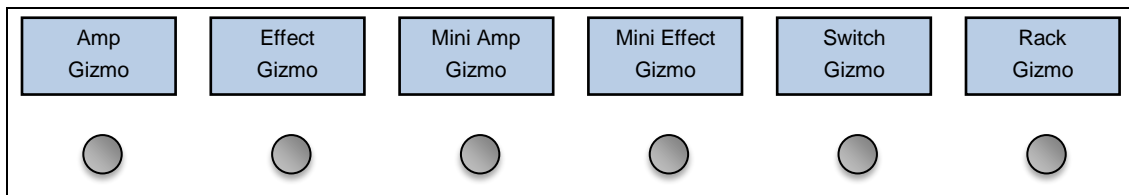

If your device (or device manufacturer) is not listed, you can select **Generic** for the manufacturer and **PC/CC Device** for the device model. This will allow you to control most effect processors and loop switchers. You will need to manually type in the device name and other parameters in the Edit Device and Edit Button menus.

If your device is listed, the Mastermind GT can set up many of the device parameters for you. What it can do varies from device to device. At the minimum, it can set up the device name and the number of presets and banks the device has. Some devices allow you to set up instant access buttons by parameter name and some will even allow you to download preset names from the device.

The Device Edit screen shows you the options available for your device:

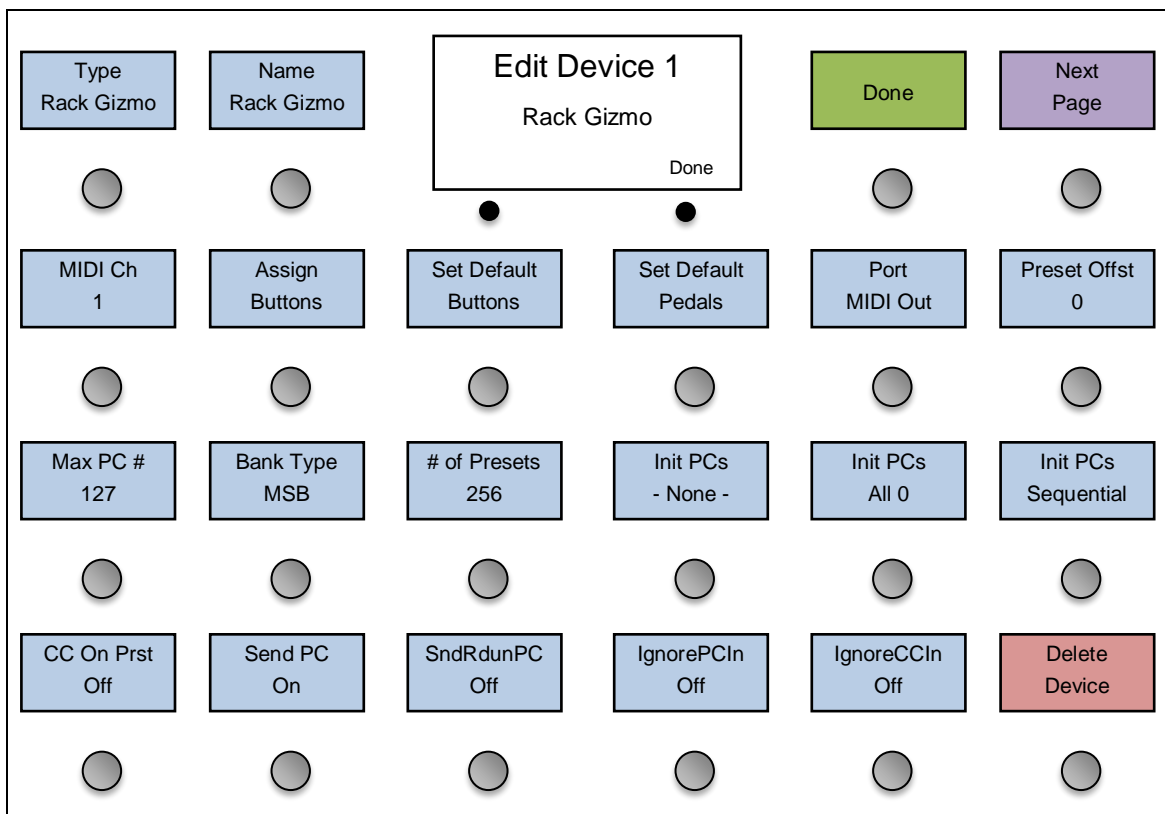

(Please note that the screens will look different based on which model of Mastermind GT you have. If not all of the available options can fit, use the **Next Page** button to see the other pages of options.)

One important parameter that needs to be set for every device is the MIDI channel (**MIDI Ch**). The MIDI channel is very important because it insures that each device receives the messages it's supposed to – and doesn't receive the messages that are intended for other devices.

Typically, each MIDI device needs to be set to its own MIDI channel. This number needs to be set here on the Mastermind GT and also on the device itself. (Most MIDI devices have a MIDI Channel or MIDI Receive Channel parameter). To set the channel on the Mastermind GT, press the **MIDI Ch** button, then select one of the 16 possible MIDI channels.

If they're available, the **Set Default Buttons**, **Set Default Pedals** and **Get Preset Names** options allow for the quickest setup. Press **Set Default Buttons**, then select a page number from the list that pops up. The buttons on the selected page will be set up to control the different features of your device. These features could be individual effects on an effect processor, audio loops on a loop switcher, or any other on/off type parameter. **Set Default Pedals** does something similar for expression pedals, setting up the expression pedals to control commonly used features on the device (typically wah and volume pedal functions).

Reading Preset Names

If you like (and if available), you can also select **Get Preset Names**. This will make the Mastermind GT download the name of every preset from your effect processor, saving you the trouble of typing them in. **Get Preset Names** brings you to the following menu:

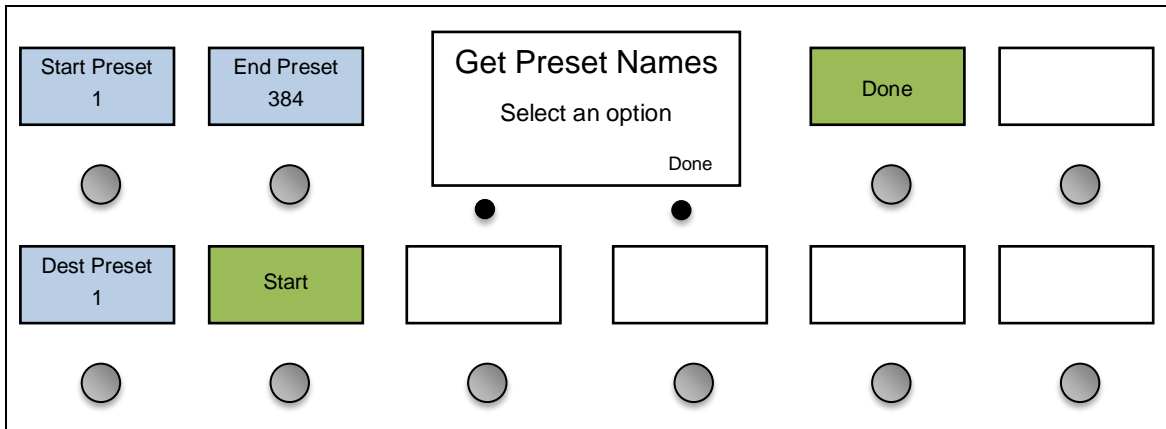

Start Preset and **End Preset** indicate the numbers of the starting and ending preset *on your effect processor* that will have their names copied. **Dest Preset** indicates the first of the presets on the Mastermind GT that will be renamed.

Once you press the **Start** button, the Mastermind GT will query your device starting at the preset indicated by **Start Preset**. The name of that preset will be copied to **Dest Preset** on the GT. The destination preset will also be set up to recall the correct preset on the effect device. The GT will then move to the next higher preset and will repeat the process. This will continue until it processes **End Preset** on the effect processor.

Reading Preset Names with Scenes

On the Axe-Fx III device, it's possible to read both preset names and scene names. Scenes are "presets within a preset", and they allow you to have different configurations of each preset that you can recall quickly. You can think of each preset as a different pedalboard and each scene determines the settings for each effect on the pedalboard, and which effects are on and which are off.

When you select the **Get Preset Names** option on an Axe-Fx III, there is an additional option, **Get Scenes**. If you leave this turned off, you can read preset names as described in the previous section. If you turn it on, you get the following options:

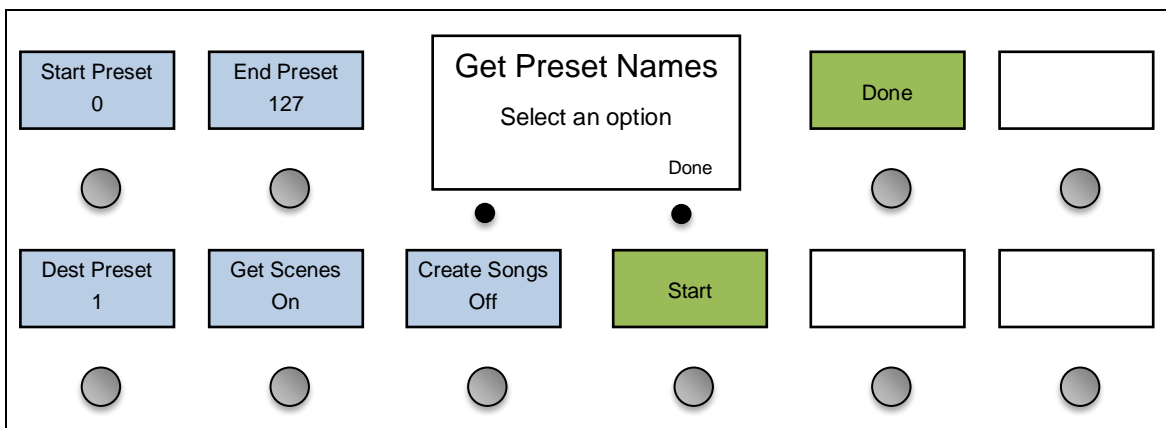

When you run this process, it will read preset names as in the previous section, but it will also read scene names from each preset and store them into each GT preset. These scene names will be displayed on any Scene buttons you may have defined. The default button configuration created by **Set Default Buttons** includes Scene buttons that appear when the GT is in IA mode. There is also a **Show Scene Names** option in Display Settings that will enable display of the current scene name in the lower row of the main display.

Scene names are stored within each GT preset, and you can edit them using the **Edit Presets / Edit Scenes** setup menu item.

Using the Create Songs Option

If you turn on the Create Songs option, the Get Preset Names process sets up your GT differently. The **Dest Preset** option will change to **Dest Song**. You will also see another option appear: **Scenes/Song**. This controls how many scenes are read from each Axe-Fx preset.

When you start this process, the Mastermind will read the preset and scene names from the Axe-Fx III and will create songs and presets based on what it reads. Each Axe-Fx preset will become a GT song, and each Axe-Fx scene will become a GT preset. **Scenes/Song** controls how many scenes are read from each preset. We recommend setting this to 6 on a Mastermind GT/22, or 5 on a Mastermind GT/10 or GT/16, because this is the number of preset buttons each model has by default.

Once you've done this, you'll see both the current preset and current scene name in the main display on the Mastermind GT. Your preset buttons will display the names of the scenes in the current Axe-Fx preset. Pressing a preset button will select a scene. Pressing Bank Up or Bank Down will move through the list of Axe-Fx presets.

The Create Songs option is recommended if you are controlling multiple MIDI devices and you would like to have other MIDI devices switch presets when you change scenes on the Axe-Fx. Using GT presets to select scenes makes this possible – selecting a scene using the GT can select presets (or make other changes) on all of your other devices. The primary limitation of this option is that you are able to download fewer presets – each scene becomes one of the GT's 768 presets, so if you have **Scenes/Song** set to 6, for example, you will be able to download 128 presets with 6 scenes each.

Setup with a Fractal Audio Axe-Fx I or II

The Axe-Fx series of effect processors are commonly used with Mastermind GTs. The Axe-Fx's advanced MIDI implementation allows the Axe-Fx and Mastermind GT to communicate to each other, with the Mastermind GT sending commands to the Axe-Fx and the Axe-Fx sending status information back to the Mastermind GT.

NOTE: THESE INSTRUCTIONS APPLY TO THE ORIGINAL AXE-FX AND AXE-FX II SERIES. AXE-FX III SUPPORT IS DISCUSSED IN THE NEXT SECTION.

Connections

This setup requires slightly different connections than a standard MIDI device would. There are two ways to do it:

Single MIDI cable – this is the simplest connection. Simply connect a standard 5-pin MIDI cable from the Mastermind GT's MIDI output to the Axe-Fx's MIDI input.

Even though the connectors on the two devices are 7-pin MIDI connectors, a 5-pin cable will work fine. The extra two pins are used for phantom power, and should be left unconnected. The Axe-Fx is not able to supply enough current to power the Mastermind GT, so a 5-pin cable is the safest option.

Make sure that the MIDI cable you use is a "5 pin active" type – a "3 pin active" MIDI cable will not work correctly. It's also important to make sure that the Mastermind GT and Axe-Fx are connected directly to each other, with no MIDI devices in between. They need to be directly connected in order to communicate correctly.

With this option, you should power the Mastermind GT normally – with its included power supply.

Phantom Power Adapter – you can also phantom power the Mastermind GT. This allows you to keep the power supply backstage in a rack, with only one MIDI cable going to the GT. We sell a phantom power adapter box, part number PPA-DIN7F-1, which is a small box that goes between the Mastermind GT and Axe-Fx. It combines the MIDI connection from the Axe-Fx and power from the AC adapter into a single 7-pin MIDI connection that goes to the Mastermind GT.

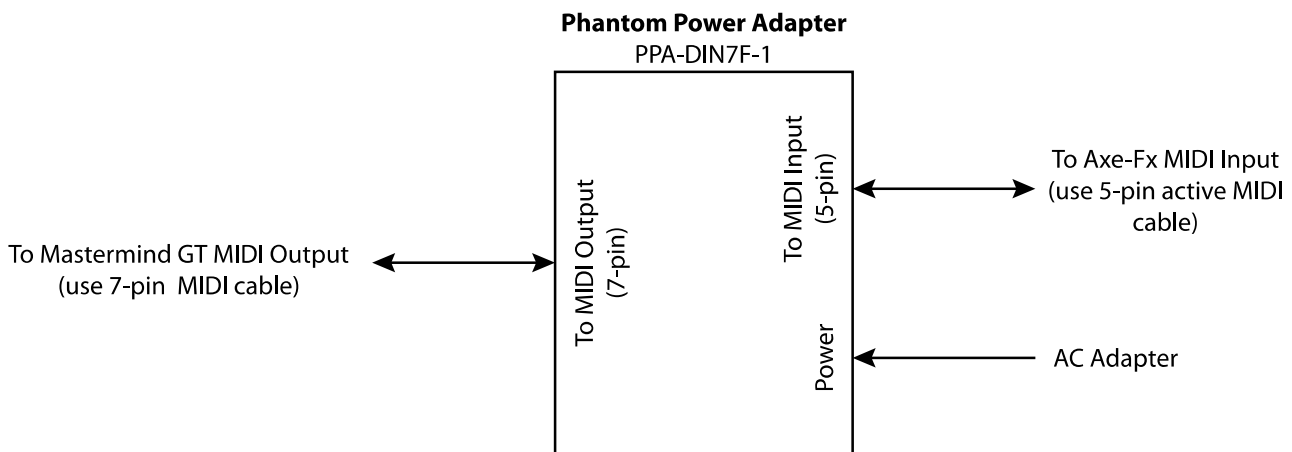

Settings

Setup on the Mastermind GT requires only a few steps:

1. In Mastermind GT setup, select **Edit Devices**.

2. Select a device slot. If you're starting with a Mastermind GT that's in the factory state, select the "Rack Gizmo" slot. If you also have a Rack Gizmo, you can leave the "Rack Gizmo" entry and instead select one of the empty slots.
3. Press the **Type** button, then select **Fractal Audio**. Next, select your Axe-Fx model from the list. Don't select any of the options that say "(slave)" after the model name. (These options are described a bit later.)
4. Press the **Set Default Buttons** button, and press **1**. This sets up button page 1 with a default set of buttons that control the Axe-Fx.
5. Press the **Set Default Pedals** button. This sets up the expression pedals to control the Axe-Fx.
6. Optional: Use the **Get Preset Names** feature to read the preset names from the Axe-Fx. This process is described in the previous section.
7. Exit setup mode.

Usage

Once it's set up, you'll see a standard configuration of preset buttons, bank buttons, and IA buttons. The preset buttons (in green) allow you to select presets on the Axe-Fx, and the bank buttons (in purple) allow you to move through the banks of presets. If your preset buttons are currently showing presets 0 through 4, pressing Bank Up will change the presets to display presets 5 through 9. Pressing Bank Up again will shift up to the next bank of presets, and pressing Bank Down will shift down one bank. The combination of bank and preset buttons allows you to access every preset on the Axe-Fx.

The blue buttons are IA (Instant Access) buttons. These control individual effect blocks in the current preset. If an IA button is not lit, that means that the effect block is not available in the current preset. If the IA button is blue, the effect is available in the current preset but is not currently turned on. If the IA button is aqua or light blue, then the effect is currently turned on. Any of the IA buttons that are lit can be pressed to turn the associated effect on or off, just like an effect pedal.

Tuner

The **Tuner** button turns on the Axe-Fx's built-in tuner and displays the tuner status on the Mastermind GT's main display. The tuner will remain on until the **Tuner** button is turned off or you select a different preset.

Tempo

The **Tempo** button allows you to tap out a tempo for time-based effects on the Axe-Fx. The settings in the current Axe-Fx preset determine which effects follow this tempo. Once it's been tapped, the Tempo button will flash at the current tempo.

Troubleshooting

If the Mastermind GT and Axe-Fx don't appear to be communicating, there are a number of things you should check:

1. Check the MIDI cables and how they're connected. This is the most common cause of problems. Make sure your cables are good – try other cables if you have them. Make sure that your 5-pin cables are the "5 pin active" type.
2. Make sure that the Axe-Fx's MIDI channel is set to the same MIDI channel as the Axe-Fx entry in the Mastermind GT's device settings. By default, these are both set to channel 1, but either could have been changed to something else.
3. In the Axe-Fx's I/O / MIDI settings page, make sure that "Send Realtime Sysex" is set to ALL.

Slave Mode

By default, the on/off state of each effect block is determined by the settings stored in the Axe-Fx's presets. When you select a preset on the Mastermind GT, the GT selects the desired preset on the Axe-Fx. The Axe-Fx then reports back to the Mastermind GT, telling it if each effect block is on, off or disabled. The IA buttons are updated to show this status.

In this "normal" mode, if you want to change which effect blocks are turned on or off in a particular preset, you need to do the editing on the Axe-Fx itself. You can't update this information on the Mastermind GT.

An alternate method is available, which we refer to "slave mode". This changes the way the Mastermind GT handles the IA buttons that control effect blocks. When a preset is selected on the GT, the GT will request a preset on the Axe-Fx, then report the status of each effect block ("chorus 1 is on", "drive 1 is off", etc.). This all happens in a fraction of a second, and the result is that the GT's settings override those on the Axe-Fx.

In slave mode, you can select which effect blocks are turned on or off simply by pressing the IA buttons on the Mastermind GT, then holding the "Page / IA Store" button for three seconds to store the new IA state to the current preset. No editing is required on the Axe-Fx itself.

Selecting Slave Mode

To select slave mode, go into **Edit Devices**, select a device slot, then press **Type**. In the list that pops up, select your Axe-Fx model, with "(slave)" shown after the model name. Then follow the steps in the Setup section above, starting with step 4.

If you want to switch to slave mode, or switch out of slave mode and have previously set up your GT to work with an Axe-Fx, it's important that you reassign all of your IA buttons using the **Set Default Buttons** or **Assign Buttons** functions. Each button has to be updated to its new settings.

Setup with a Fractal Audio Axe-Fx III

The Mastermind GT supports the Axe-Fx III processor, which expands on the previous models with many more effect blocks, named scenes and effect block channels.

Connections

There are two methods you can use for connecting your Axe-Fx III.

Two MIDI cables – Use two standard 5-pin MIDI cables. One connects from the Mastermind GT's MIDI Out jack to the Axe-Fx's MIDI Input. The other connects the Mastermind GT's Remote In jack to the Axe-Fx's MIDI output.

Even though the connectors on the Mastermind GT are 7-pin MIDI connectors, a 5-pin cable will work fine. Just make sure the gap in the pins is facing upward when you plug it in.

With this option, you should power the Mastermind GT normally – with its included power supply.

Phantom Power Adapter – you can also phantom power the Mastermind GT. This allows you to keep the power supply backstage in a rack, with only one MIDI cable going to the GT. We sell a phantom power adapter box, part number PPA-DIN7F-2, which is a small box that goes between the Mastermind GT and Axe-Fx III. It combines the MIDI connections from the Axe-Fx III and power from the GT's AC adapter into a single 7-pin MIDI connection that goes to the Mastermind GT.

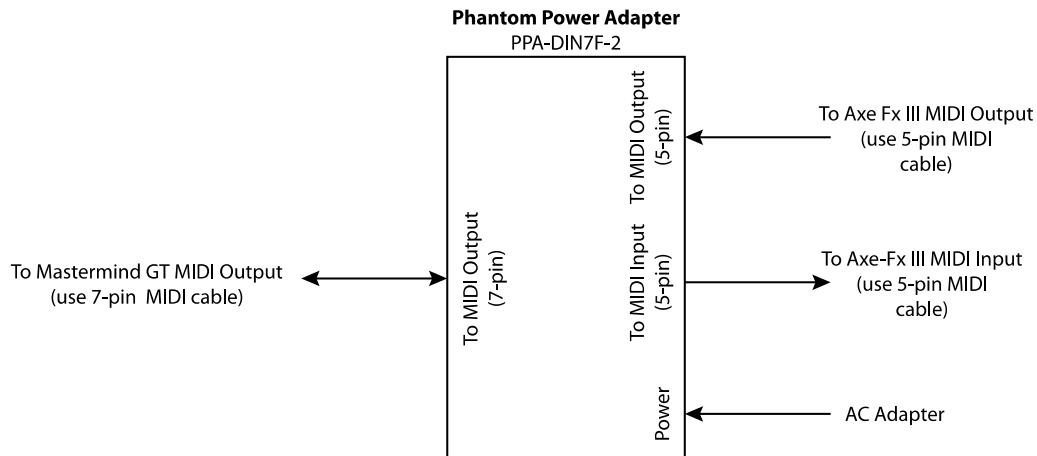

Settings

There are a few important settings that need to be made on the Axe-Fx III. Go into setup on the Axe-Fx III, and use the "down" button to move down to the MIDI/Remote option, then press Select. Make the following changes:

1. Set **MIDI Channel** to 1
2. Set **Program Change** to On
3. Set **Send Realtime Sysex** to On

Setup on the Mastermind GT requires only a few steps:

1. In Mastermind GT setup, select **Edit Devices**.
2. Select a device slot. If you're starting with a Mastermind GT that's in the factory state, select the "Effect Gizmo" slot and you can overwrite it. If you also have an Effect Gizmo, you can leave the "Effect Gizmo" entry and instead select one of the empty slots.

3. Press the **Type** button, then select **Fractal Audio**. Next, select **Axe-Fx III**.
4. Press the **Set Default Buttons** button and press **1**. This sets up button page 1 with a default set of buttons that control the Axe-Fx III.
5. Press the **Set Default Pedals** button. This sets up the GT's expression pedals to control the Axe-Fx. There's a little more expression pedal setup required on the Axe-Fx, which is described in the next subsection.
6. Optional: Use the **Get Preset Names** feature to read the preset names from the Axe-Fx. This process is described in the [Reading Preset Names with Scenes](#) section.
7. Exit setup mode.

Expression Pedal Setup

Following the previous steps sets up the GT's expression pedals to send the correct CC numbers. Some more setup on the Axe-Fx is required.

In the Axe-Fx's setup menu, go to MIDI/Remote and select the External page. Set External Control 1 to CC11, External Control 2 to CC12, External Control 3 to CC13 and External Control 4 to CC14.

To assign an expression pedal to an effect parameter, edit the effect in the Axe-Fx. Select the parameter you want the expression pedal to control and press the Modifier knob on the Axe-Fx. Set Source to "External Control 1" to assign it to the first expression pedal, "External Control 2" to assign it to the second expression pedal, etc. For a more detailed description, please refer to the "MODIFIER TUTORIAL: WAH PEDAL" section in the Axe-Fx III manual.

Usage

Once it's set up, you'll see a standard configuration of preset buttons, bank buttons, and IA buttons. The preset and bank buttons will work in one of two ways:

If you followed the instructions in the [Using the Create Songs Option](#) section:

The current preset name and current scene name are displayed in the main display. The green preset buttons show all of the scenes that you've defined in the current preset. Pressing a green button selects a scene. Pressing Bank Up or Bank Down allows you to move through the list of Axe-Fx presets and select them. As you move through the list of presets, the green buttons will update to display the scenes available for the current preset.

If you didn't follow those instructions, or read preset names without reading scenes:

Pressing the green preset buttons will select Axe-Fx presets. If you used the **Get Preset Names** option, the buttons will display the Axe-Fx preset names. Otherwise, the buttons will be numbered: Preset 1, Preset 2, etc. Pressing the Bank Up or Bank Down buttons will move you through the banks of Axe-Fx presets. If your preset buttons are currently showing presets 1 through 5, pressing Bank Up will change the presets to display presets 6 through 10. Pressing Bank Up again will shift up to the next bank of presets and pressing Bank Down will shift down one bank. The combination of bank and preset buttons allows you to access every preset on the Axe-Fx.

The blue buttons are IA (Instant Access) buttons. These control individual effect blocks in the current preset. If an IA button is not lit, that means that the effect block is not available in the current preset. If the IA button is blue, the effect is available in the current preset but is not currently turned on. If the IA button is aqua or light blue, then the effect is currently turned on. Any of the IA buttons that are lit can be pressed to turn the associated effect on or off, just like an effect pedal.

The second line in these IA buttons indicates which channel is active. Most effect blocks have four channels and each can have different settings for its effect parameters. Holding one of these IA buttons for 2 seconds pops up a menu that allows you to select one of the four available channels.

IA Mode

The white IA Mode button switches the preset and bank buttons to their secondary functions. When using an Axe-Fx III, the preset buttons become Scene select buttons, and will display scene names if you have run Get Preset Names. The Bank and Page/IA Store buttons will change to additional effect block buttons.

Tuner

The **Tuner** button turns on the Axe-Fx's built-in tuner and displays the tuner status on the Mastermind GT's main display. The tuner will remain on until the **Tuner** button is turned off or you select a different preset.

Tempo

The **Tempo** button allows you to tap out a tempo for time-based effects on the Axe-Fx. The settings in the current Axe-Fx preset determine which effects follow this tempo. Once it's been tapped, the Tempo button will flash at the current tempo.

Troubleshooting

If the Mastermind GT and Axe-Fx don't appear to be communicating, there are a number of things you should check:

1. Check the MIDI cables and how they're connected. This is the most common cause of problems. Make sure your cables are good – try other cables if you have them.
2. If you're using a phantom power box, make sure that **MIDI Bidir** (bidirectional MIDI) is turned on in MIDI Settings.
3. Make sure that the Axe-Fx's MIDI channel is set to the same MIDI channel as the Axe-Fx entry in the Mastermind GT's device settings. By default, these are both set to channel 1, but either could have been changed to something else.
4. In the Axe-Fx's MIDI/Remote settings page, make sure that settings are set as described earlier in this section.

Technical Details

Axe-Fx III support works differently than other devices. The Axe-Fx III is actually being controlled by Sysex messages sent from the GT. However, the GT is really designed to work with CCs - the built-in device database only uses CC numbers, for example. What's worse, the Axe-Fx III ships without any CC numbers predefined at all. Using CCs would require you to go in and manually set all of the CC numbers in the Axe-Fx to match the ones defined in the GT.

To get around this, we use fake CC numbers, which are translated by the software into Sysex messages behind the scenes. This allows you to continue using the typical Assign CCs and Set Default Buttons features in the GT without so much configuration needed on the Axe-Fx.

CC Values

CC values are also a bit different than normal. In addition to the standard value 0 for bypass and value 127 for active, there are values that select the effect channel:

- Value 0: Bypass effect block
- Value 1: Select channel A
- Value 2: Select channel B
- Value 3: Select channel C
- Value 4: Select channel D
- Value 5: Select channel E
- Value 6: Select channel F
- Value 127: Enable effect block

This allows us to use one CC number that can select either effect state or effect channel.

If you look at the default button settings, you can see examples of how all of this works. Each IA button uses

the 0 and 127 values to turn an effect block on and off, and the hold function uses values 1-4 to select effect channel.

Get Preset Names with Scenes

Running the **Get Preset Names** process with **Get Scenes** turned on will retrieve preset names from the Axe-Fx and will also read the scene names from each preset. Scene names are stored in each GT preset, and they can be edited in the **Edit Preset / Scene Names** menu. These scene names will automatically be displayed in any Scene buttons you have defined, and also in the lower row of the main screen if **Scene Names** is turned on.

Get Preset Names with Scenes and Create Songs

When you run **Get Preset Names** and have both **Get Scenes** and **Create Songs** turned on, the following things will happen:

- The GT will switch into song and setlist mode
- Each selected Axe-Fx preset name will be written to a GT song
- Scenes within each Axe-Fx preset will have their names written into GT presets. (This can be anywhere from 1 to 8 scenes per Axe-Fx preset, which you can choose using the **Scenes / Song** parameter)
- Each GT preset will be assigned to the appropriate GT song
- Each GT preset will be set to select the correct Axe-Fx preset and scene
- The current scene number will be stored in each GT preset. Because each preset selects a single scene, only one scene name is stored per preset

So, in the end you get one GT song for each Axe-Fx preset, and one GT preset for each Axe-Fx scene. Pressing a GT preset button will select a scene, pressing Bank Up or Bank Down selects an Axe-Fx preset.

Setup with a Kemper Profiling Amp

The Kemper Profiling Amp (or KPA) is another device that is frequently used with the Mastermind GT. The KPA has an extensive MIDI implementation that allows it to communicate bidirectionally with the Mastermind GT, reporting effect block status, effect types, tempo and tuner data.

Connections

The KPA needs two MIDI cables to communicate to the Mastermind GT, one for input and one for output. There are two ways you can make the connection:

Two MIDI cables – this is the simplest connection. Simply connect two standard 5-pin MIDI cables: one from the Mastermind GT's MIDI output to the KPA's MIDI input, and one from the Mastermind GT's Remote In to the KPA's MIDI output.

These cables can be "3-pin active" or "5-pin active" types – either is fine. Even though the MIDI connectors on the Mastermind GT are 7-pin, it's okay to use 5-pin MIDI cables – the two extra pins are used only for phantom power and can be left unconnected.

With this option, you should power the Mastermind GT normally – with its included power supply.

Phantom Power Adapter – you can also phantom power the Mastermind GT. This allows you to keep the power supply backstage in a rack, with only one MIDI cable going to the GT. We sell a phantom power adapter box, part number PPA-DIN7F-2, which is a small box that goes between the Mastermind GT and KPA. It combines both MIDI connections from the KPA and power from the AC adapter into a single 7-pin MIDI connection that goes to the Mastermind GT. This adapter also has the advantage of improving the grounding of the MIDI connections, greatly reducing any noise generated by the MIDI data stream.

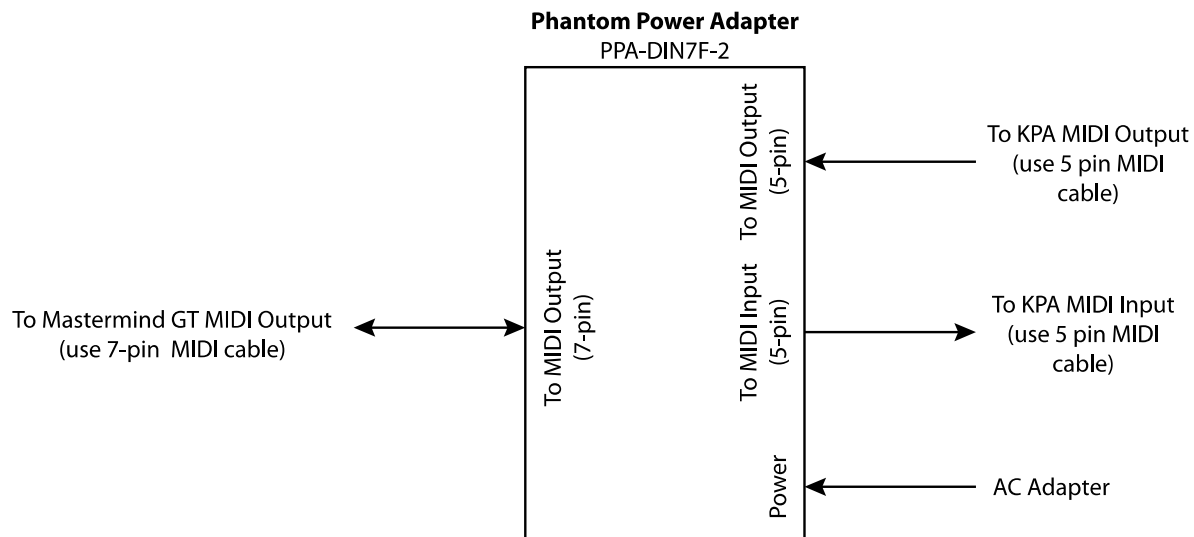

Settings

Setup on the Mastermind GT requires only a few steps:

1. In Mastermind GT setup, select **Edit Devices**.
2. Select a device slot. If you're starting with a Mastermind GT that's in the factory state, select the "Rack Gizmo" slot. If you also have a Rack Gizmo, you can leave the "Rack Gizmo" entry and instead select one of the empty slots.
3. Press the **Type** button, then select **Kemper**. Next, select **KPA**. Don't select the "**KPA (slave)**" option – this option is described a bit later.

4. Press the **Set Default Buttons** button, and press **1**. This sets up button page 1 with a default set of buttons that control the KPA.
5. Press the **Set Default Pedals** button. This sets up the expression pedals to control the KPA.
6. Optional: Turn on the **Auto Names** feature. This feature allows the Mastermind GT to read the performance and slot names from the KPA when the KPA is in Performance Mode. The GT's preset buttons and bank names will automatically be updated as you select new banks (or Performances, as they're called on the KPA).
7. Optional: If you're not using **Auto Names**, you can use the **Get Preset Names** feature instead. This feature downloads preset names from the KPA and uses them to set the Mastermind GT's preset names. This works in KPA's Performance Mode, and will also work in Browse Mode if you have "Browse Mode Program Changes" set on the KPA.
8. If using the **Auto Names** feature, make sure you have exactly five preset buttons visible on your button page. The Mastermind GT/22 has six preset buttons in its default configuration, so you need to change the sixth button to be something other than a preset button. If the number of preset buttons isn't exactly five, the wrong presets will be recalled.
9. Exit setup mode.

Usage

Once it's set up, you'll see a standard configuration of preset buttons, bank buttons, and IA buttons. The preset buttons (in green) allow you to select presets on the KPA, and the bank buttons (in purple) allow you to move through the banks of presets. If you're using the **Auto Names** feature, the bank buttons will select each performance in the KPA, and the preset buttons will select the individual slots in the performance.

The blue buttons are IA (Instant Access) buttons. These control individual effect blocks in the current preset. If an IA button is not lit, that means that the effect block is not available in the current preset. If the IA button is blue, the effect is available in the current preset but is not currently turned on. If the IA button is aqua or light blue, then the effect is currently turned on. Any of the IA buttons that are lit can be pressed to turn the associated effect on or off, just like an effect pedal.

When controlling the KPA, the IA buttons will also show the type of effect that's loaded in each slot for the current preset.

Tuner

The **Tuner** button turns on the KPA's built-in tuner and displays the tuner status on the Mastermind GT's main display. The tuner will remain on until the **Tuner** button is turned off or you select a different preset.

Tempo

The **Tempo** button allows you to tap out a tempo for time-based effects on the KPA. The settings in the current KPA preset determine which effects follow this tempo. Once it's been tapped, the Tempo button will flash at the current tempo.

Troubleshooting

If the Mastermind GT and KPA don't appear to be communicating, there are a number of things you should check:

1. Check the MIDI cables and how they're connected. This is the most common cause of problems. Make sure your cables are good – try other cables if you have them.
2. Make sure that the KPA's MIDI channel is set to the same MIDI channel as the KPA entry in the Mastermind GT's device settings. By default, these are both set to channel 1, but either could have been changed to something else.

Slave Mode

By default, the on/off state of each effect block is determined by the settings stored in the KPA's presets. When you select a preset on the Mastermind GT, the GT selects the desired preset on the KPA. The KPA then reports

back to the Mastermind GT, telling it if each effect block is on, off or disabled. The IA buttons are updated to show this status.

In this "normal" mode, if you want to change which effect blocks are turned on or off in a particular preset, you need to do the editing on the KPA itself. You can't update this information on the Mastermind GT.

An alternate method is available, which we refer to "slave mode". This changes the way the Mastermind GT handles the IA buttons that control effect blocks. When a preset is selected on the GT, the GT will request a preset on the KPA, then report the status of each effect block ("Stomp A is on", "Delay is off", etc.). This all happens in a fraction of a second, and the result is that the GT's settings override those on the KPA.

In slave mode, you can select which effect blocks are turned on or off simply by pressing the IA buttons on the Mastermind GT, then holding the "Page / IA Store" button for three seconds to store the new IA state to the current preset. No editing is required on the KPA itself.

Selecting Slave Mode

To select slave mode, go into **Edit Devices**, select a device slot, then press **Type**. In the list that pops up, select **Kemper**, then **KPA (slave)**. Then follow the steps in the Setup section above, starting with step 4.

If you want to switch to slave mode, or switch out of slave mode and have previously set up your GT to work with a KPA, it's important that you reassign all of your IA buttons using the **Set Default Buttons** or **Assign Buttons** functions. Each button has to be updated to its new settings.

Setup with RJM Music Products

The Mastermind GT is designed to work with other RJM Music products with a minimum of setup.

Connections

The Mastermind GT only needs a single MIDI cable to connect to one of our products. You can use a standard 5-pin cable to make the connection, and power the Mastermind GT with its own power supply.

You can also phantom power the Mastermind GT. This allows you to keep the power supply backstage in a rack, with only one MIDI cable going to the GT. Any of our products that have a 7-pin MIDI input connector (which is most of them) can phantom power the Mastermind GT directly. Simply connect a 7-pin MIDI cable from the device's MIDI input to the Mastermind GT's MIDI Output.

Important Notes on Phantom Power!

When phantom powering the Mastermind GT, it's very important to follow these rules:

1. Use the Mastermind GT's power supply to power the device that's supplying the phantom power! The AC adapter included with most of our products is not sufficient to power the Mastermind GT. The Mastermind GT's power supply is large enough to power the GT plus another device, and works with all of our MIDI products.
2. Don't plug anything into the Mastermind GT's power input jack!

Chaining Multiple Devices

When controlling multiple MIDI devices, only the device that's directly connected to the Mastermind GT can provide phantom power. You can add multiple devices to the MIDI chain by connecting the MIDI Thru of the one device to the MIDI input of the next. 5-pin MIDI cables are sufficient for these additional connections.

Setup

Setup for RJM Music devices uses the standard process described in a previous section:

1. In Mastermind GT setup, select **Edit Devices**.
2. Select a device slot. If you're starting with a Mastermind GT that's in the factory state, select the "Rack Gizmo" slot.
3. Press the **Type** button, then select **RJM Music**. Next, select the name of your RJM product.
4. Set the **MIDI Channel** parameter. For simplicity, we recommend setting your first device to MIDI channel 1, your second device to MIDI channel 2, etc.
5. On the device you're controlling, be sure to set its MIDI channel accordingly. The MIDI channel number must match the number you've assigned to it in the GT's settings. Please consult the device's user's manual for instructions on how to set its MIDI channel.
6. Back on the GT, press the **Set Default Buttons** button, and press **1**. This sets up button page 1 with a default set of buttons to control your device. If you have more than one device, you may wish to buttons for each device to different pages. If this is the case, select a page other than number 1. After assigning the default buttons, you can always move the buttons around to your liking (see the Editing Buttons section for details).
7. Exit setup mode.

Editing Buttons

The basic device setup in the Initial Setup section is typically enough you get you started using a new device. However, you'll probably want to change the button arrangement of the controller to your liking. On the Mastermind GT, any button can be set to perform any function, so be sure to take advantage of this ability!

Swap Buttons

The simplest way to rearrange buttons is to use the **Swap Buttons** function. This function simply swaps the location of two buttons. To swap buttons, hold both soft buttons to enter Setup Mode, then Select the **Swap Buttons** option.

The button select screen will appear, flashing all buttons to indicate that you need to select a button:

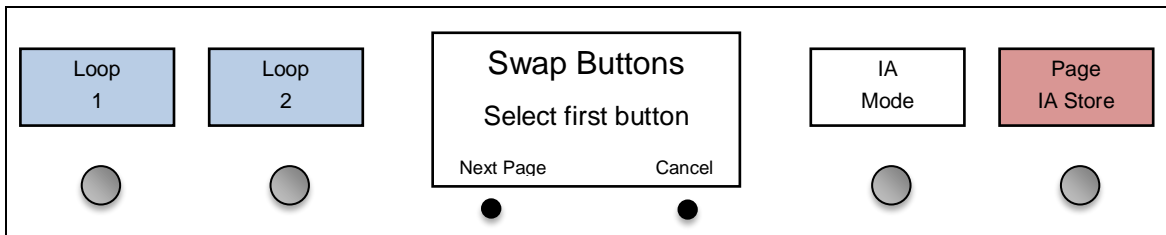

You can use the left soft button to switch button pages if needed, or press the right soft button to cancel the swap.

After selecting the first button, you are then asked for the second button:

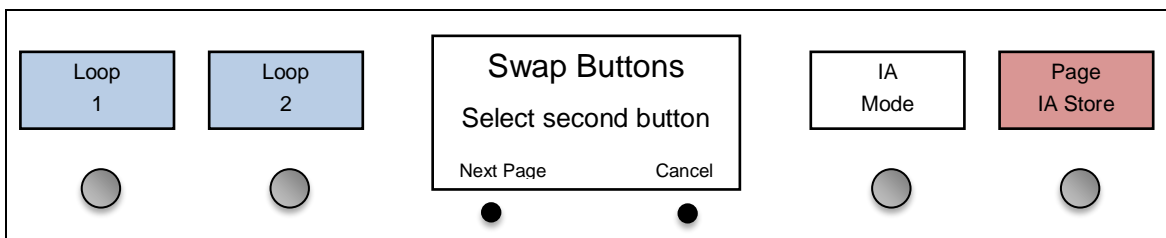

Once the second button is selected, the two buttons will be swapped and you will be taken to the main setup menu.

Copy Button

You can also copy a button from one location to another. Unlike swapping, copying asks for a source button and a destination button. The source button is copied to the destination, overwriting any settings on the destination button. You will be left with two identical copies of the source button.

This is typically used to have the same button appear on more than one page. Copies of a button all act the same, and when one button is turned on or off, all of the copies also turn on or off accordingly.

The Copy Button function is accessed in the same way as the Swap Buttons function – it's located right next to the Swap Buttons function in the main setup menu.

A Special Note on Preset Buttons

Preset buttons operate differently than other buttons – copying or swapping them will not work as you might expect. Preset buttons don't refer to a specific preset, but rather show presets in the current bank, which is selected using the bank up and down buttons.

On power up, the preset buttons will display presets starting at preset 1. The Mastermind GT scans the buttons starting in the upper left corner, then proceeds left to right and top to bottom, looking for preset buttons. The first preset button it finds will show preset 1, the next button it finds will show preset 2, etc. Because of this, swapping preset buttons will not rearrange the order of presets – the buttons will still have presets assigned to them based on their physical location on the Mastermind GT.

You can change how the Mastermind GT assigns presets to preset buttons. There's a parameter called Preset Index that allows you to change the order in which presets are assigned to buttons. All buttons are assigned preset index 0 by default. To change the order of preset assignment, set the preset index to 1 for the button that should display the first preset in the current bank, set the preset index to 2 on the button that should display the second preset, in the current bank, etc. You can rearrange the preset buttons in any way you like using this method.

Assign Buttons

Most devices in the Mastermind GT's device database have information about the various parameters that can be controlled on the device. The Assign Buttons function allows you to quickly assign a button to control one of these parameters.

To access the Assign Buttons function, select **Edit Devices** from the main menu, then select the device you wish to control. Select the **Assign Buttons** option

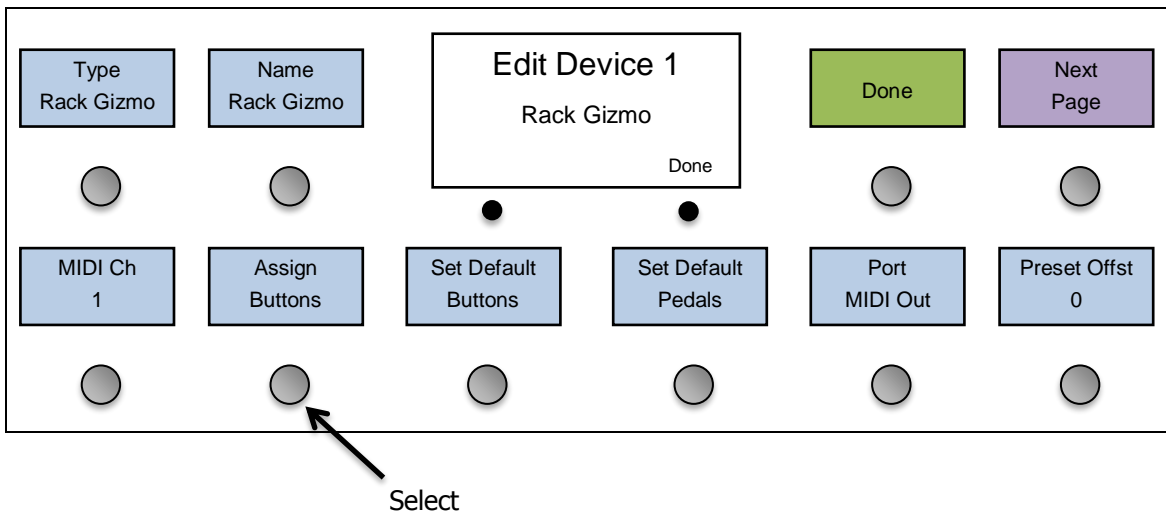

You will be shown a list of parameters that are available on the device.

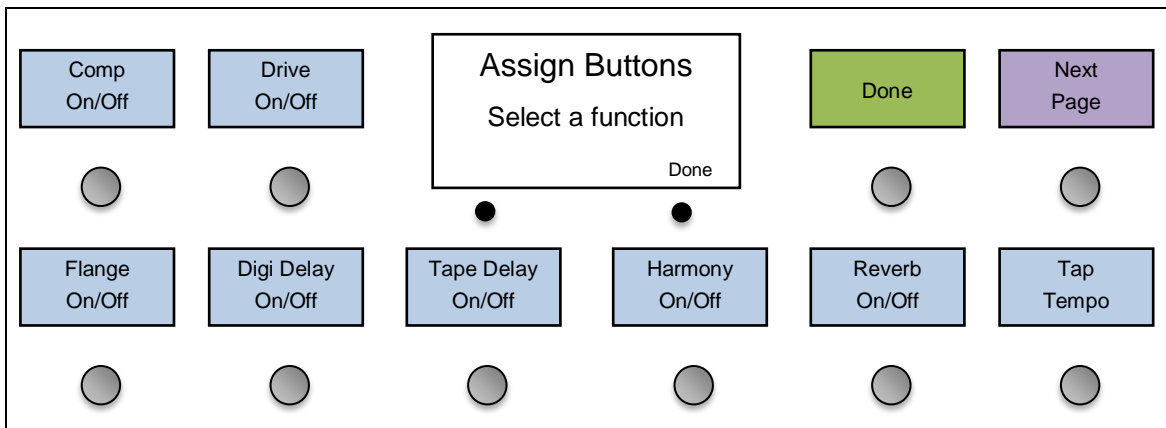

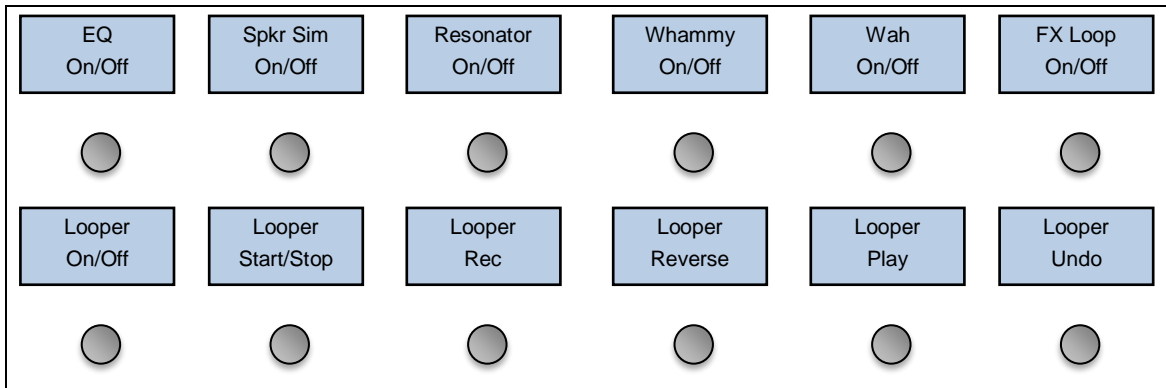

If the list of functions takes up more than one page, the **Next Page** buttons will be shown. This will let you move between the pages of functions.

Once a function is selected, the menu will ask which button should receive the function. This is done using the Button Selection menu described earlier. You will be asked if you wish to replace or add the function to the button.

Replace will delete the existing contents of the button, then copy the new function to the button. The button will be turned into an instant access button with the newly selected function assigned to it.

Add will add the newly selected function to the button, preserving the button's type and list of existing functions. When pressed, the button will activate or deactivate all of the functions assigned to it.

The Assign Buttons menu is designed to be a quick way to set up your buttons. To do more detailed editing, you can use the Edit Button menu, which is described next.

Low Level Editing

If you need more control over your buttons, you can edit the Actions assigned to each button. Button Actions are a list of things a button does when it's pressed. This could be sending a MIDI message or changing a parameter or mode on the Mastermind GT itself. You can define up to 20 actions for each button.

By using the **Set Default Buttons** and **Assign Buttons** functions as described in the previous sections, Actions have already been assigned to buttons. In the **Edit Buttons** menu, now press the **Button Actions** button. The Button Actions screen will be displayed, where you can see the list of actions:

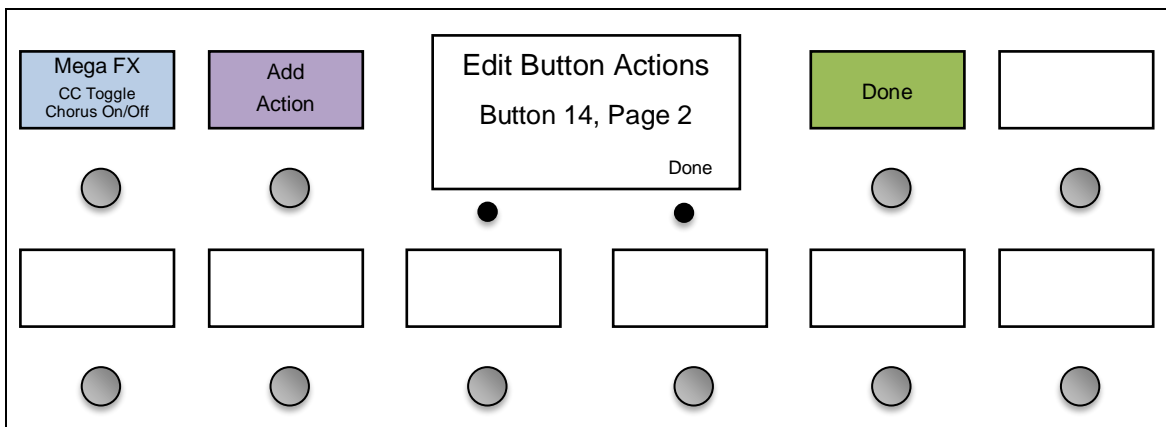

In this example, we see that there is one action defined: to the "Mega FX" device, it is sending a CC message to control the Chorus On/Off parameter. You can either add another action to this button by pressing the **Add**

Action button, or you can edit the existing Action by pressing its button. In either case, you will be taken to the Action Edit menu:

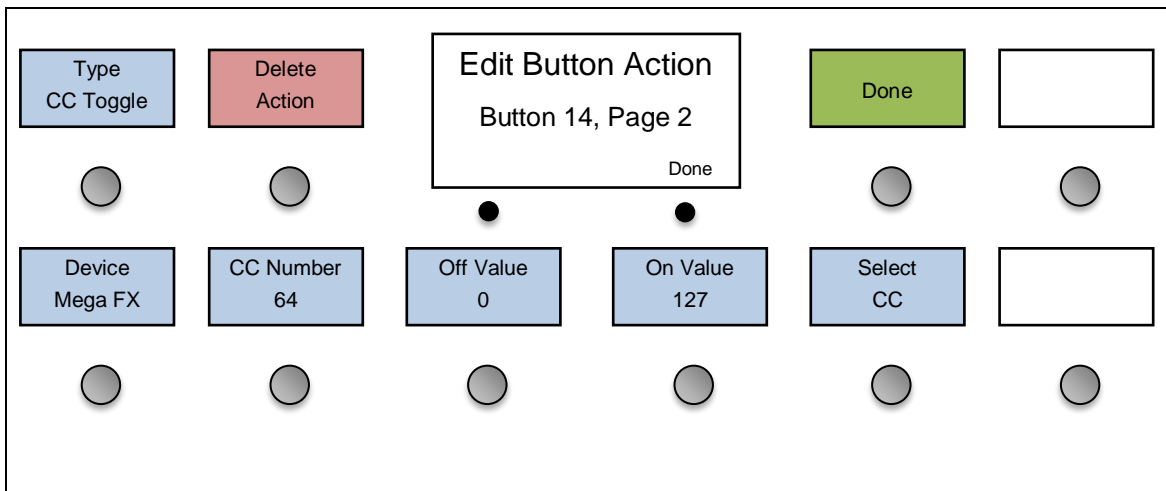

The **Type** parameter allows you to select the action you want to perform. This could be sending a MIDI CC, PC or Note message, or it could be a system Action. For now, we'll discuss CC (Continuous Controller) Actions because they're the most commonly used Action type.

Once the Action type is chosen, you can select which device this Action applies to. Pressing the **Device** button brings up a list of the devices you've defined. Then, once a device is chosen you can use the Select CC option (if available) to choose which parameter this action will operate on (for example delay or chorus). You can also use the other menu items to directly edit the CC number and the CC values sent when the button is turned on or off.

You can continue this process, adding multiple Actions to a button. When a button has more than one Action defined, it will perform all of the Actions in the list, in order from left to right, top to bottom. So, if you wanted to, you could have a single button enable an effect on one processor, turn on several effect loops on a loop switcher, play a note on a synthesizer and start a sequencer!

The various Action types and their parameters are described in more detail in the Action Edit section.

Hold Buttons

A button can be set up to have two different functions: one when the button is pressed normally, and one when the button is held. To do this, enter the **Edit Buttons** menu and select the desired button. The Edit Button screen will appear:

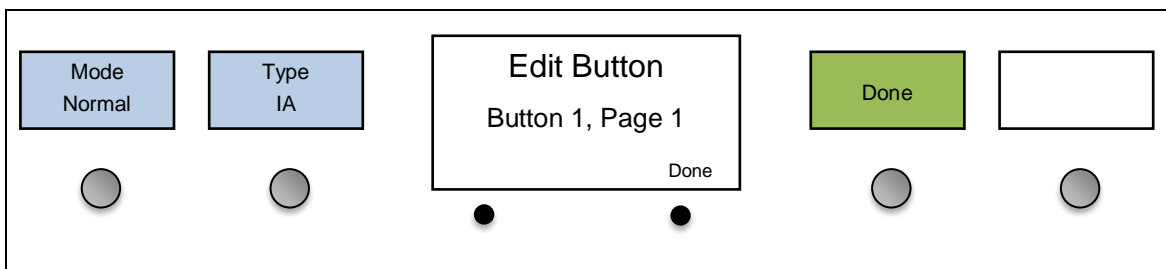

Press the **Mode** button to switch the button from "Normal" to "Hold". The menu will change:



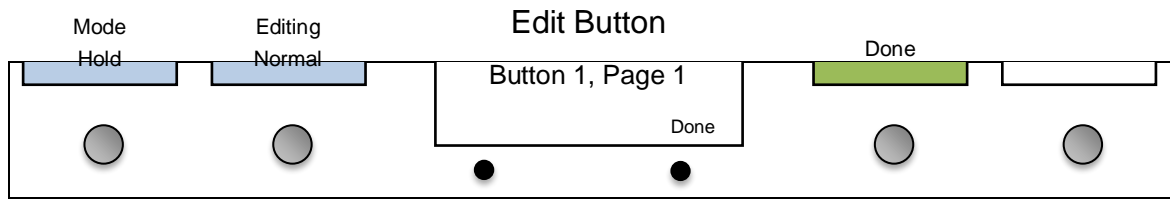

The **Editing** parameter will now control whether you are editing the button’s normal settings or the button’s hold settings. Each button can do something completely different for its normal and hold functions. Most of the parameters available for a normal function can also be set for a hold function, although some parameters like color and momentary are not available.

You can adjust the amount of time a button needs to be held down before activating the hold function. The parameter is called **Hold mSec** and is in the main setup menu.

When a button is set up to have a hold function, the button will display with the normal function name in the top line and the hold function name in the bottom line.

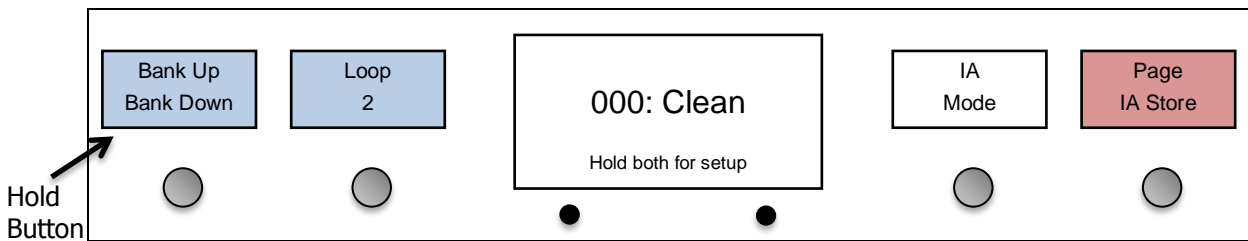

Hold functions can also have their own colors. When editing a hold function, there are **On Color** and **Both Color** settings. These are used in conjunction with the button’s normal color settings as follows:

- Normal Function Off, Hold Function Off – uses normal function’s **Off Color**
- Normal Function On, Hold Function Off – uses normal function’s **On Color**
- Normal Function Off, Hold Function On – uses hold function’s **On Color**
- Normal Function On, Hold Function On – uses hold function’s **Both Color**

You can set either of the Hold Function’s colors to “None”, which causes the hold function’s color to be ignored, using the normal function’s colors instead.

Cycle Buttons

IA buttons can also be set up to cycle, that is, to switch between up to 4 different states instead of just switching on or off. To enable an IA button to cycle, turn on the **IA Cycle** parameter in the Edit Button screen. This will add more parameters: **Step 1 Name, Step 1 Color, Step 2 Name, Step 2 Color, Step 3 Name, Step 3 Color, Step 4 Name, Step 4 Color**. Use these parameters to set up the name and the color of each step in the cycle.

The next step is to edit the button’s action list using the **Button Actions** option in the Edit Button menu. Put a **System / Step** action at the end of each step, except the last one. Each time you press the IA button, it will skip to the next step action, and execute all of the actions up to the next step action. Once the end of the action list is reached, it will start back at the beginning

For example, to set up an IA button to adjust volume level in four steps, you can set up an action list like this:

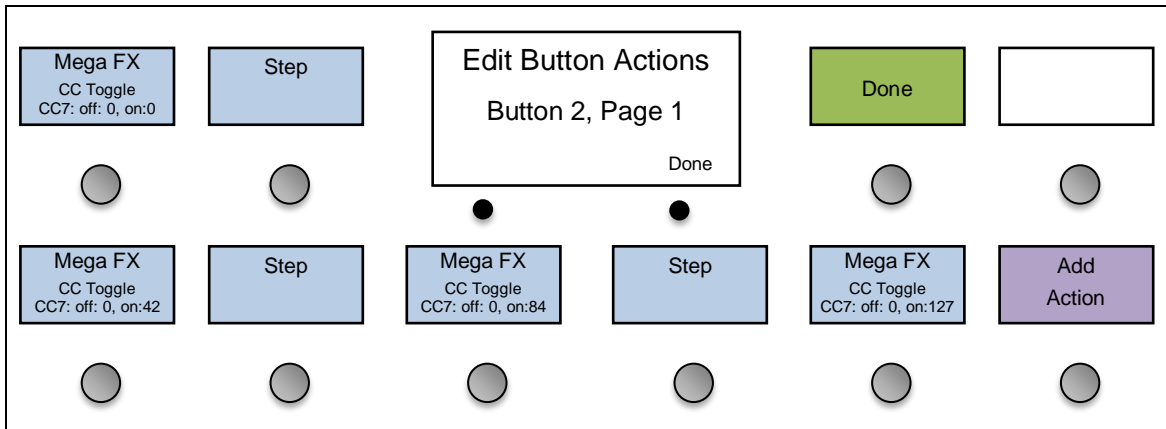

The IA button will send CC7 with a value of 0. The next time the button is pressed, it will send CC7 with a value of 42. Subsequent presses will send CC7 with a value of 84, then 127. The next press will send CC7, value 0 again.

When an IA button is set to cycle, only the "On" values of each action are used. The "Off" values are always ignored.

Cycle Menu

The **Cycle** Menu option is available when **IA Cycle** is enabled. When enabled, it changes the way the IA Cycle button operates. Instead of going through the 4 steps one step at a time, a menu of choices pops up allowing you to select one of the four, allowing faster access to each option.

Editing Presets

The Mastermind GT's presets are the primary way to get many things to happen with a single button press. Each preset can do the following:

1. Sends a MIDI Program Change (PC) message to any of your connected MIDI devices.
2. Perform up to 10 actions, each of which can send any MIDI message or activate another function on the Mastermind GT.
3. Change the state of each of the IA buttons and force the buttons to send their MIDI messages.
4. Change the currently visible button page, and load a local button page if requested.
5. Load new settings for expression pedals and external switches (if requested)

These steps are performed in the order shown above – PC messages are sent first, button actions are executed next, etc.

To edit presets, select the **Edit Presets** option from the main setup menu. You will be presented with a list of all of your presets. You can use the **Next Page** button to move through the list.

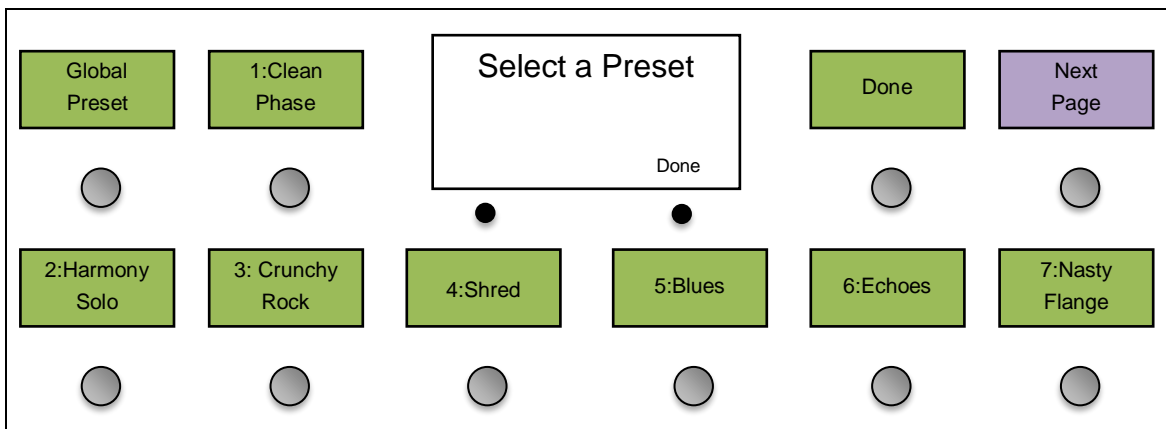

Press one of the buttons and the Preset Edit menu is displayed.

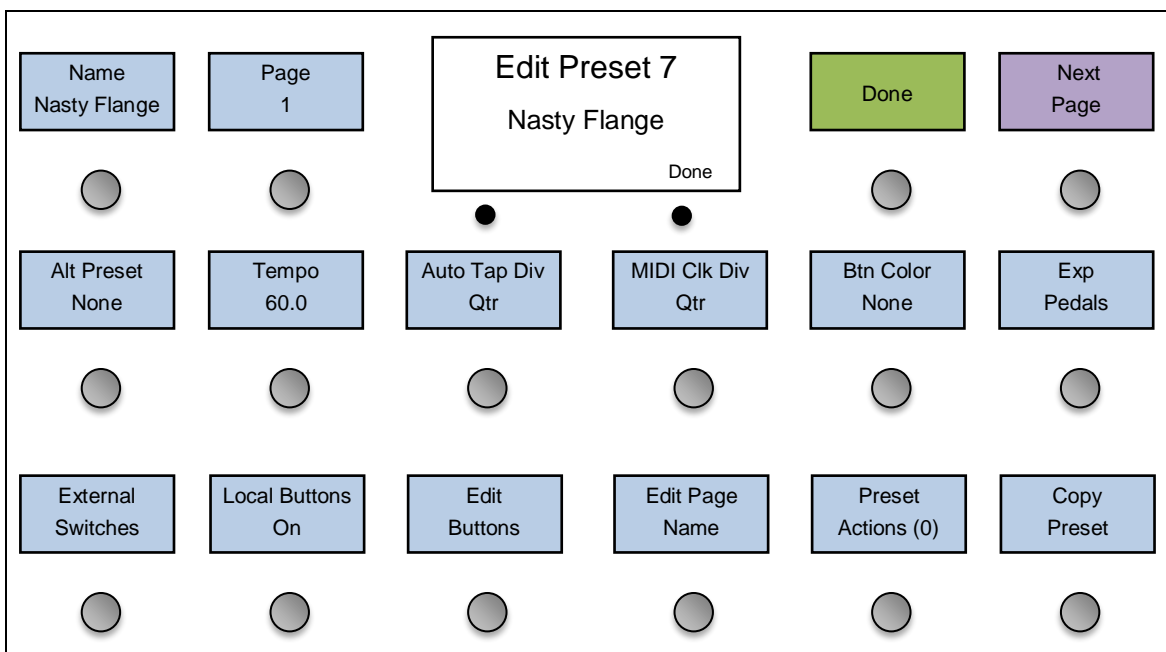

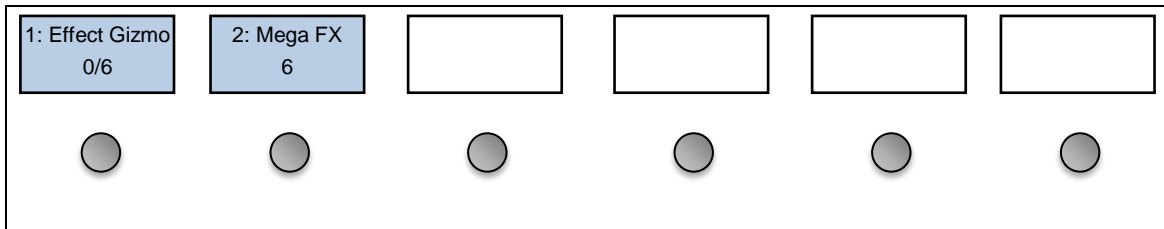

Name

This parameter allows you to edit the name of the preset that will be displayed in the preset buttons and main display when the preset is selected.

Button Page

The **Page** option allows you to choose which button page is displayed when the preset is selected. Any of the 16 button pages can be displayed, or you can select the "Same" option to leave the button page unchanged. You can also load a local button page for this preset. This option is described later in this section.

This option only has an effect if **Auto Page Select** is turned on in global settings.

Alt Preset

Each preset can have an alternate preset number assigned to it. If you have the global setting **Preset 2nd Press** set to "Alt", then pressing the currently selected preset button a second time will switch you to that preset's alternate preset. Pressing the preset button again will switch you back to the main preset. The default setting "None" indicates that this preset has no alternate preset.

Tempo

You can set a tempo for each preset. When the preset is loaded, the tempo will automatically change to this new value. This affects MIDI clock if enabled, and also the Auto Tap feature. The tempo can be set to any value up to 400 BPM, and it can also be set to special values: "None" (no tempo is active), "Song" (use the current song's tempo) and "Same" (keep the same tempo). Please refer to the [Tap Tempo and MIDI Clock](#) section for more details.

MIDI Clock Div / Auto Tap Div

These settings allow you to set tap divisions for both the MIDI Clock and Auto Tap features, so that you can have the Mastermind GT send mathematically related tempos. Please refer to the [Tap Tempo and MIDI Clock](#) section for more details.

Btn Color

This setting allows you to set the color of a preset button when this preset is selected. This color overrides any color that's set for the preset button. Set to "None" to keep the default preset button color.

Expression Pedals and External Switches

You can choose to override the global settings for any expression pedals and external switches. Select **Exp Pedals** or **External Switches**, then select the desired pedal or switch number. Turn **Override** On, and then you will be presented with a page where you can edit the pedal or switch's settings for this preset. Please refer to the [Expression Pedal](#) or [Button Edit](#) section for more details on these parameters.

Local Button Page

Each preset can have its own local button page, which is specific to the current preset. This page is loaded when the preset is selected, and the page takes the place of button page 16. When **Local Buttons** is turned on, you will see two options appear: **Edit Buttons** and **Edit Page Name**. **Edit Buttons** works as described in

the [Editing Buttons](#) section of the manual, but will allow you to edit this preset's local button page. **Edit Page Name** allows you to set a name for the local button page.

Preset Actions

Each preset can also execute up to 10 actions. These actions are the same that can be assigned to IA buttons, and are described in the [Low Level Editing](#) part of the [Editing Buttons](#) section. Preset actions can be used to send any type of MIDI message, and perform other operations on the GT.

Edit Scenes

When using an Axe-Fx III, you can select different scenes as well as presets. Each preset has 8 possible scenes. Using this option, you can edit the names of the 8 different scenes for each preset.

IA Button State

The state of each IA button can be stored in each preset, which allows you to turn IA buttons on or off automatically when a preset is selected. This feature is an exception in that it is not edited in the Setup Menu. Instead, IA state is edited using the normal operating mode. The process is as follows:

1. Select a preset
2. Manually turn IA buttons on or off as desired
3. Hold the **Page / IA Store** or **IA Store** button for 3 seconds to store the state to the current preset.

Please note that this only works for IA buttons that have the **SndOnPrst** (Send on Preset Change) and **UpdOnPrst** (Update on Preset Change) settings turned on. If these settings are turned off, the button will not be affected by preset changes.

PC Messages

Each of the Mastermind GT's presets can send different MIDI Program Change messages to each of the connected devices. By default, the Mastermind GT sends consecutive program change numbers to each device. Selecting preset 1 sends program change 0 to each device, selecting preset 2 sends program change 1 to each device, preset 3 sends program change 2, etc. For devices such as effect processors, you will probably need to customize the program change numbers so that the preset buttons call up your favorite effect programs.

There are 16 buttons that show any devices that are defined, and the program / bank numbers that are set to be sent to the device for this preset. A program number may be displayed as a single number or as a pair of numbers (bank/program), depending on how the device handles bank and program numbers.

Pressing any of the active device buttons brings you to the PC Edit menu:

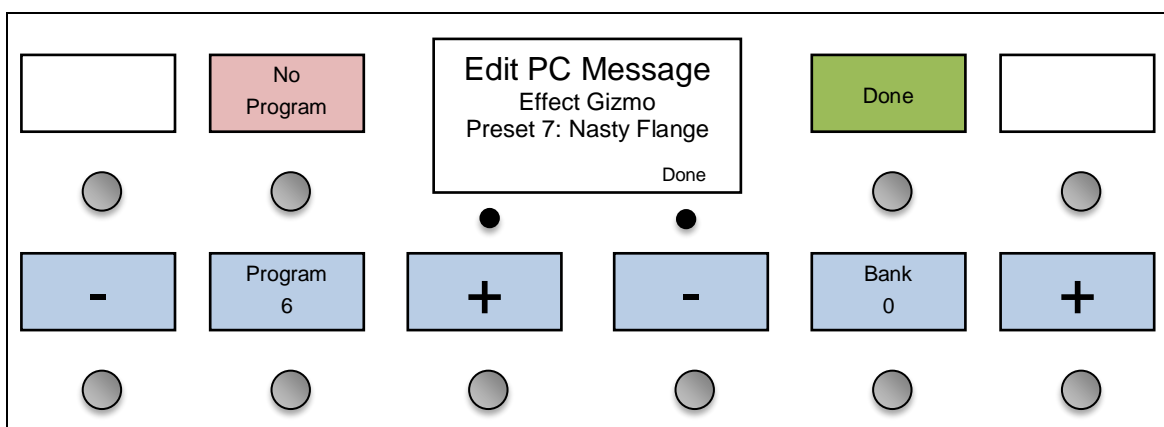

You can press the **Program** or **Bank** buttons to edit the program (PC) and bank numbers, or press the **+** or **-** buttons to adjust the numbers up or down. Pressing **No Program** will prevent the Mastermind GT from sending a program change to the device when loading this preset. Press the **Done** button when the numbers are set correctly.

The Mastermind GT will send the corresponding PC message(s) to the device as you edit, so you can verify that the correct preset is being selected.

Song and Setlist Mode

For live performances, your Mastermind GT presets can be arranged into **Songs** and **Setlists**. Using this feature allows you to group presets by song and makes it easy to rearrange those songs for each performance.

A **Song** is a group of presets – up to 16 of them – that are selected for use in a particular song. Each preset is typically chosen for the sounds needed in different parts of a song: intro, verse, chorus, bridge, solo, etc. Each preset in a song can be chosen from any of the 768 presets defined in the system, and presets can be used in more than one song.

A **Setlist** is an ordered list that represents the songs you're going to play in a particular performance. You press a button to move to the next song in your setlist as you finish each song.

When Song and Setlist mode is active, the Bank Up and Bank Down buttons move from song to song instead of moving from bank to bank. When a song is selected, the preset buttons on the current button page display the presets assigned to the song. If there are more presets in the song than there are visible preset buttons, the remaining presets will not be displayed.

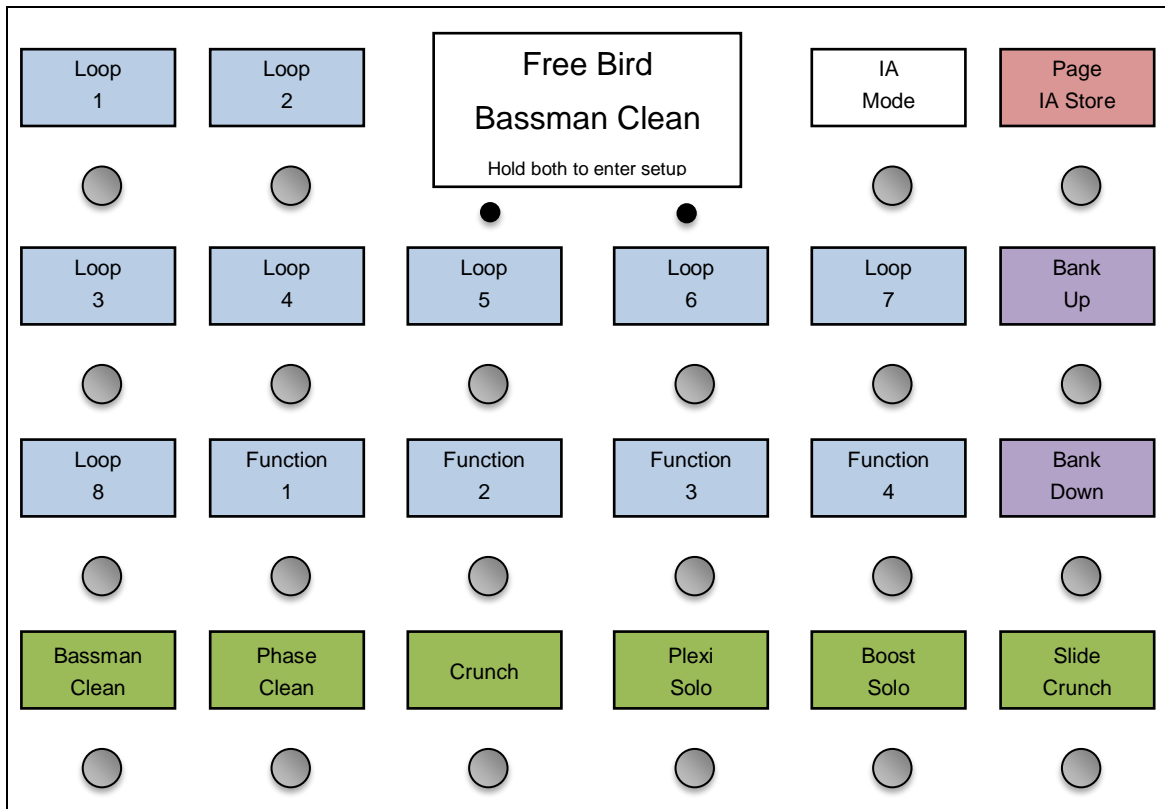

Editing Songs

The first step in setting up for Song and Setlist mode is to edit your songs. Hold both buttons under the screen to enter Setup Mode. Select **Edit Songs** to get to the Song Edit menu. You will first be shown a list of songs that are defined in the system. Select the song you wish to edit from this list.

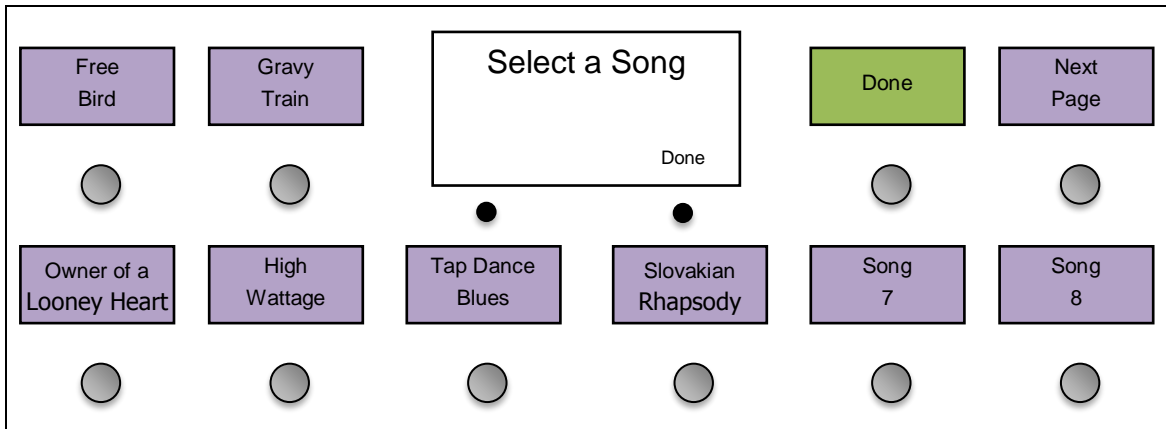

The songs are displayed in purple to differentiate them from setlists (which are displayed in white) and presets (which are displayed in green). Select a song from the list, using the Next Page button if needed to get to other pages of songs. There are 1008 songs available for you to edit. The default name for each song is "Song x", where x is the song number, but you can change this name to anything you like in the next menu.

Selecting a song brings up the Song Edit menu. From this menu, you can edit the song's name and assign up to 16 presets to the song. The Tempo setting can be used to set a tempo for this song, which will be active if MIDI Clock is turned on. See the [Tap Tempo and MIDI Clock](#) section for more details.



Pressing any of the green preset buttons will bring up a menu of all of your presets, allowing you to select which preset goes in that slot. When assigning presets to a song, start in the upper left slot and proceed left to right and top to bottom – when in performance mode, the presets will be shown in the available preset buttons in this same order. You can also edit the song's name using the **Name** button.

Editing Setlists

Once all of your songs have been created, you can use a setlist to put them in the order you're going to play them in a performance. You can define up to 64 setlists for different performances, and you can have up to 100 songs in a setlist.

In the Setup Menu, select Edit Setlist. You are presented with a list of all 64 setlists:

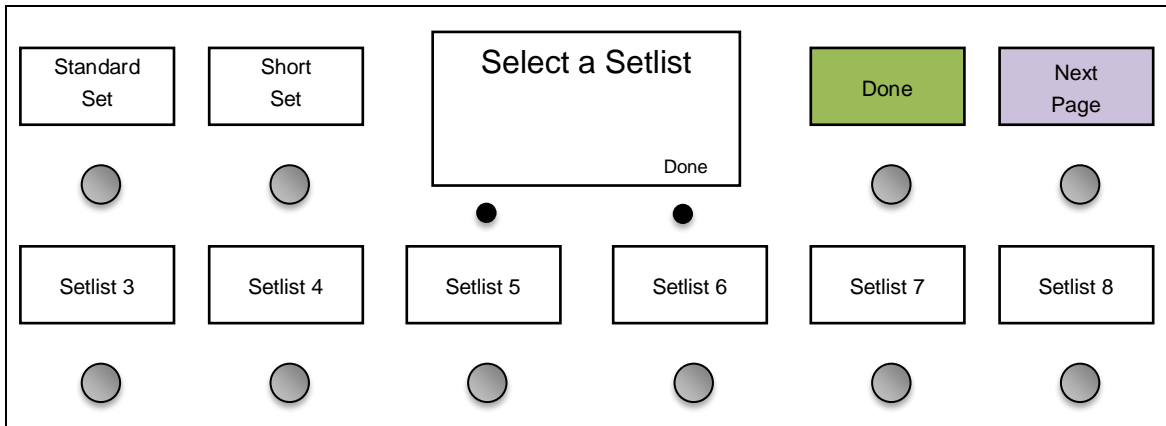

Select one of the lists and the Setlist Edit menu will be displayed:

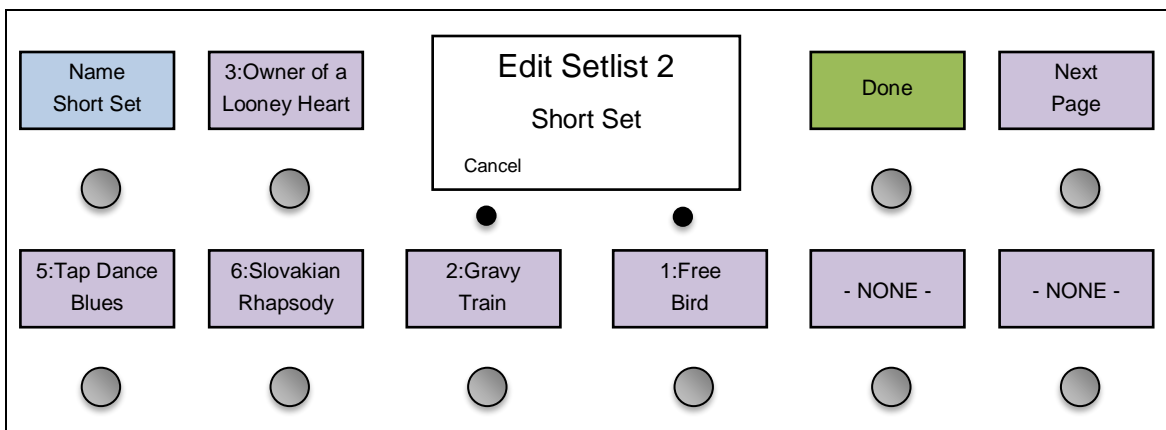

Just like you add presets to a song, you also add songs to a setlist by pressing one of the song buttons, then selecting the song that should go in that slot. As with a song, you can edit the setlist name using the **Name** button.

Using a Setlist

Once your songs and setlists are defined, you're ready to use one of your setlists in a performance. Enter Setup Mode, then use the Set List option to select which setlist is active.

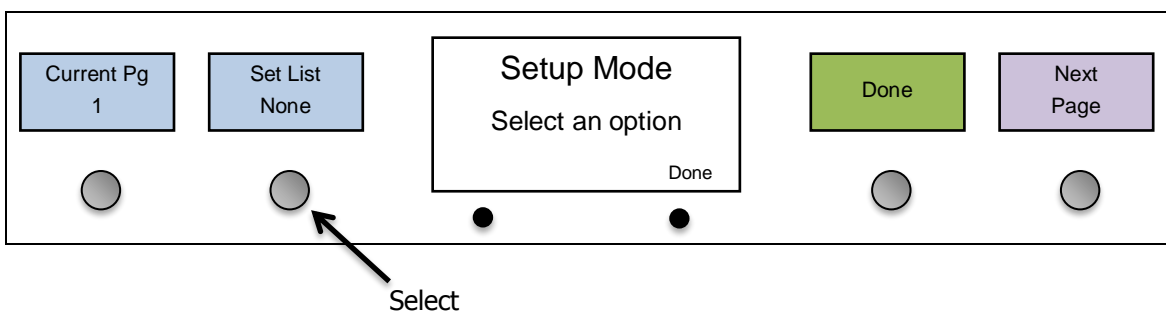

In the menu that pops up, you can either choose your desired set list, choose "All Songs" which puts all 1008 songs in one large setlist, or choose "None" to select no setlist and return to normal preset and bank mode.

Expression Pedals

The Mastermind GT has four ports that allow you to connect external expression pedals. An expression pedal can be used with MIDI-capable effects processors to provide real time control of different parameters: volume level, echo rate, etc. The Mastermind GT translates the position of the pedal to MIDI Continuous Controller messages and sends them out the MIDI Out port. The effects processor receives these messages and alters the effects accordingly.

Using Setup Mode, you can set each expression pedal to set the controller number, minimum and maximum values and which device should receive the controller messages. By default, the pedals send CC#7 through CC#10 to the first MIDI device.

Many expression pedals on the market will work. Pedals that have a stereo (TRS) 1/4" output jack and have the potentiometer wiper connected to the ring conductor of the output jack will definitely work. The Rocktron Hex and Korg XVP-10 are examples of pedals that work well, and the Boss FV-500 and Roland EV-5 are examples of pedals that don't work well.

Note! Even if an expression pedal does not have the correct polarity, you can still fix it with a specially made cable. Connecting it to the Mastermind GT with a 1/4-inch TRS cable that swaps the tip and ring conductors on one end will allow you to use any Roland/Boss type pedal.

You can also use a standard volume pedal as an expression pedal. For this you need a 1/4" Y-cable, also known as an insert cable. The stereo end of the Y cable plugs into the Mastermind GT and the two mono ends plug into the input and output of the volume pedal:

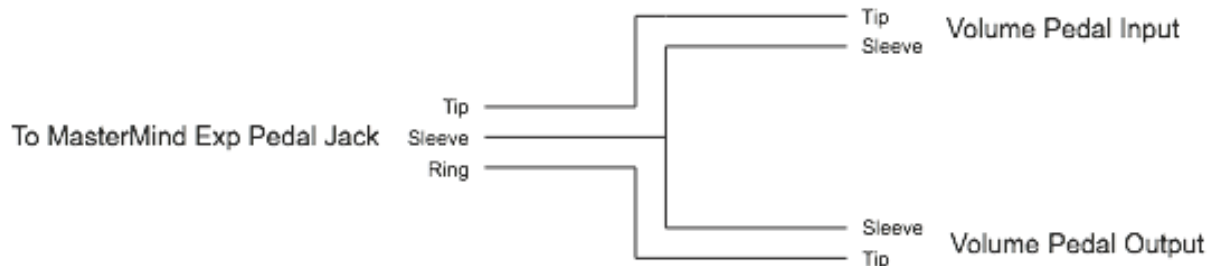

The Mission Engineering SP1-RJM

Mission Engineering makes a model of its SP1 expression pedal that's designed specifically to work with the Mastermind GT. This pedal has a built in toe switch and LED which works as an external switch. The toe switch can perform any function that one of the Mastermind GT's built-in buttons can, and is edited using the [External Switches](#) menu.

To connect the SP1-RJM to the Mastermind GT, you will need two 1/4-inch TRS cables. The first one connects from the pedal's Output 1 jack to one of the Expression Pedal inputs on the Mastermind GT. The second cable connects from the pedal's Output 2 jack to one of the External Switch inputs on the Mastermind GT.

Expression Pedal Setup

You can set up your expression pedals by selecting the **Exp Pedals** option from the main Setup Menu. You will be prompted to select which pedal you'd like to edit, then you will be brought to the Expression Pedal menu:

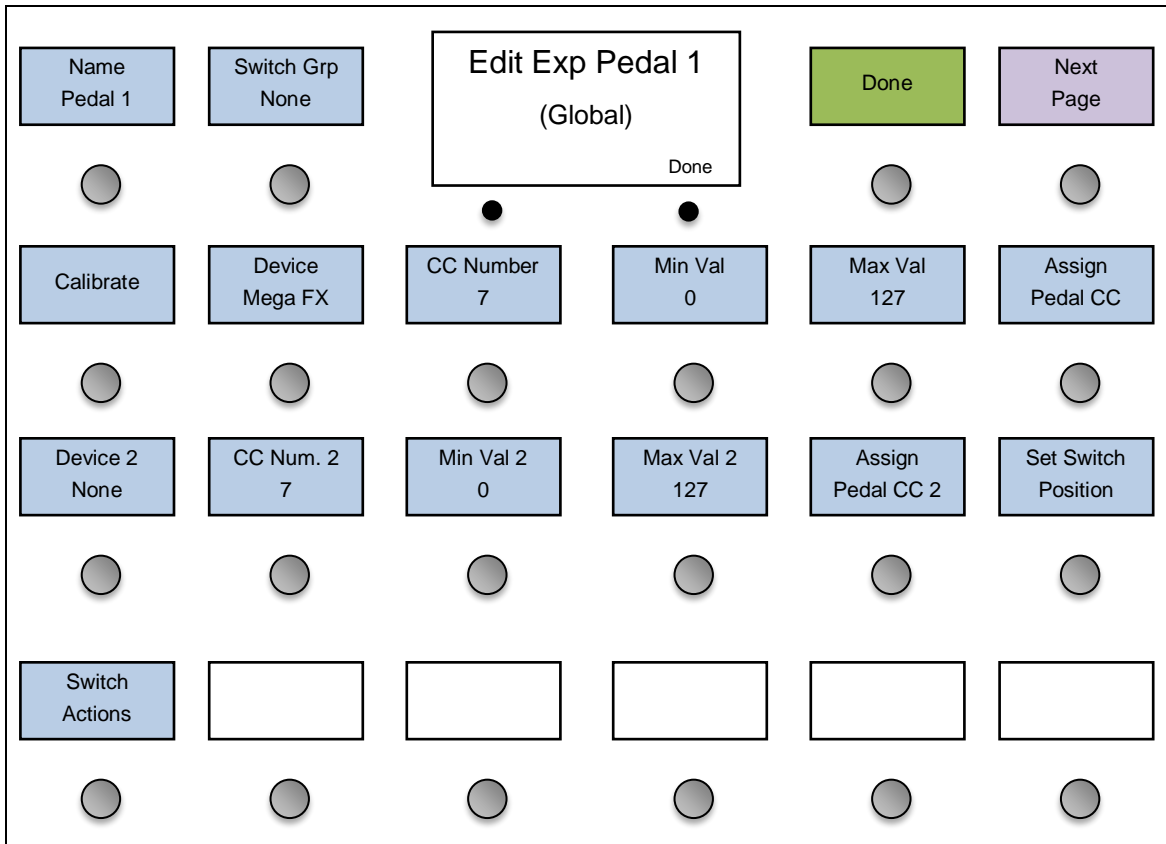

The first time you connect a particular expression pedal to the Mastermind GT, you will first want to calibrate it. Expression pedals vary from model to model, and calibrating the pedal insures that the Mastermind GT will always be able to send the correct values for the pedal's position. Simply press the **Calibrate** button, then move the expression all the way up and all the way down. Press the **Done** button once this is complete.

Basic setup of the expression pedal works like this:

- 1). Use the **Device** button to select the device you wish to control with the expression pedal.
- 2). If the option is available for your device, press the **Assign Pedal CC** button. You will be presented with a list of parameters that can be controlled by the expression pedal. Select one of these functions, and the rest of the parameters will be set for you.
- 3). If the **Assign Pedal CC** option is not available, you can manually set the CC number and minimum/maximum values for the pedal. You can find these numbers in your effect device's manual.
- 4). Some devices, such as the Eventide pedals and the TC Electronic G-Major, support a "learning" function. This means the effect device configures itself based on the messages it's receiving from the Mastermind GT. If you have one of these effect processors, turn on the learning function and move the expression pedal you wish to have control the parameter. The device will automatically adapt itself to the CC number being sent by the Mastermind GT.

The second set of parameters (all labeled with a number **2**) can be used to send a second set of CC messages. This allows you to control multiple devices at the same time and/or cross-fade between two sounds. If the **Device 2** parameter is set to **None**, then the second CC is not sent by this pedal.

Setting Up The Expression Pedal Position Switch

Each expression pedal can be set to turn a parameter on and off based on the position of the pedal. This is especially useful for turning an effect off when the pedal is raised all the way.

To set this up, you first need to select which parameter you wish to control. If you're using the expression pedal to control a wah effect, you would want to have the expression pedal switch control the effect processor's "Wah" or "Wah On/Off" parameter.

Press **Switch Actions**, then **Add Action**, which will take you to the Edit Action menu:

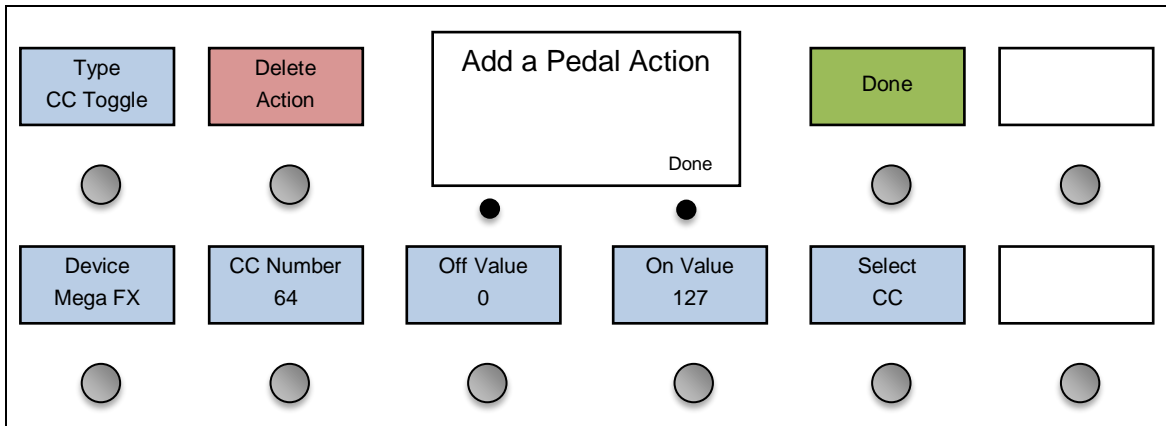

If the **Select CC** option is available, use it to select the function to control from a list of available functions:

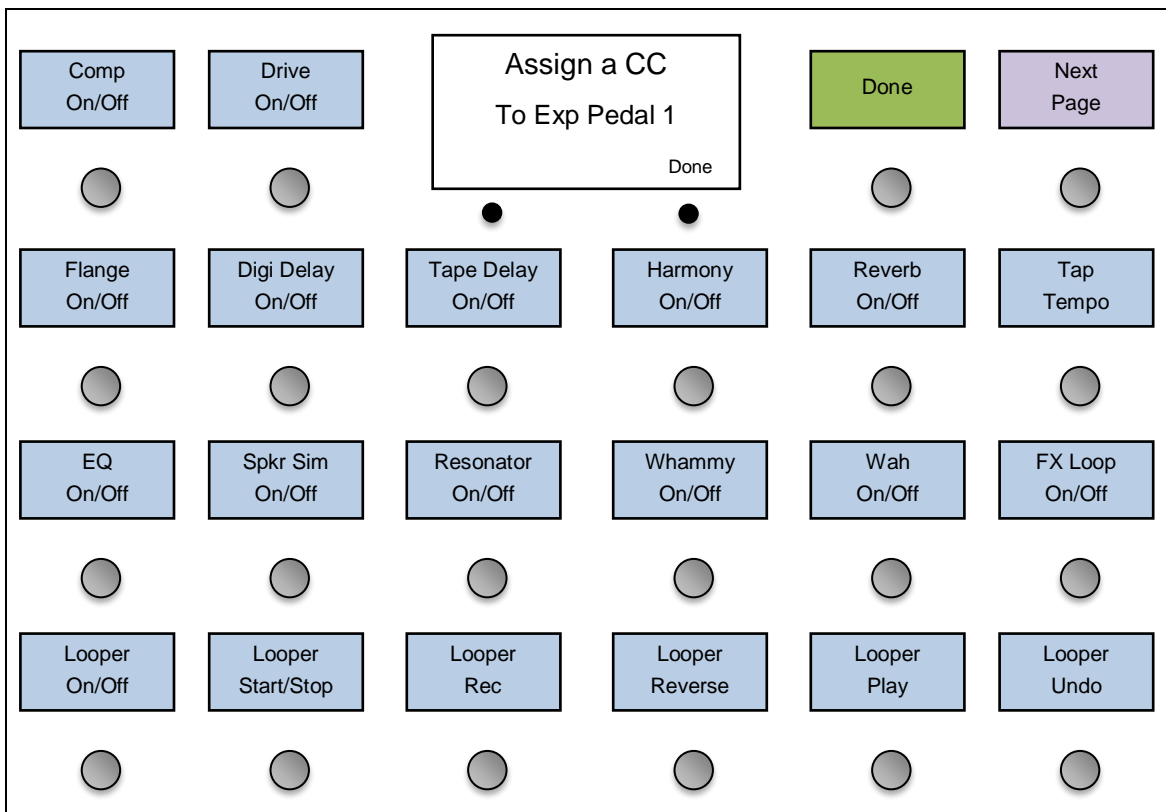

If there is more than one page of functions, the **Next Page** button will be available to allow you to move through the pages.

If **Select CC** is not available, you can manually edit the CC number, on value and off value to suit the device you're controlling.

Once you've finished with selecting the function you wish to control, press the **Done** soft button. You will return to the Expression Pedal menu.

The last step is to choose at what point in the pedal's travel the switch happens. Move the pedal to that spot (typically not quite all the way down or not quite all the way up), then press **Set Switch Position**. The pedal position will be remembered and the selected function will switch on and off as you move the pedal up and down. When the pedal goes below the saved switch position, the switch is considered to be on, when the pedal moves up above the switch position, the switch is considered to be off. There is an **Invert Switch** setting that reverses this. If you want the switch to be on when the pedal moves up above the switch position, turn the **Invert Switch** setting on.

External Switches

The Mastermind GT supports up to four external switches. These can be used to add switches to remote locations, to add different types of switches for specialized functions like tap tempo, or simply to increase the number of available switches.

There are two external switch jacks on the rear of the Mastermind GT labeled "Switch 1/2" and "Switch 3/4". Each jack can take a single switch or a double switch with a TRS (tip-ring-sleeve) plug. A single switch should use a TRS plug with the switch connected to the tip and ground, and the ring conductor unconnected to anything. If an LED is wired in parallel with the switch with the cathode connected to the shield of the TRS connector, the Mastermind GT will light the LED when the switch is on.

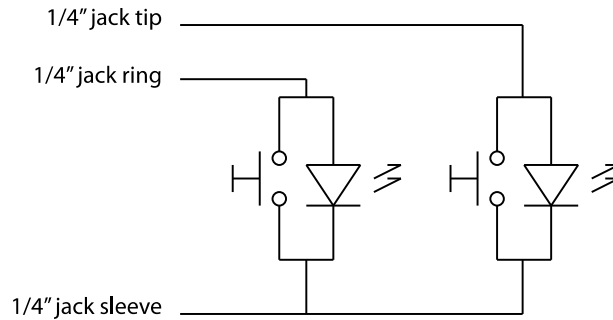

Mastermind GT External Switch Wiring Diagram

(Note: if you're building your own external switch, please note that the switch must be momentary and normally open, and the LED should be a type with a low forward voltage. Typically, this means red, yellow or green LEDs. Blue or white LEDs will not work.)

RJM Music sells single and dual external switches made to work correctly with the Mastermind GT, and Mission Engineering's SP1-RJM expression pedal includes a toe switch (similar to the on/off switch on a wah pedal) with an LED that can work as an external switch for the Mastermind GT.

External switches have global settings which can be edited in the main Setup Menu. You can also override the global settings in any preset by selecting the **External Switches** option and turning on the **Override** parameter. External switches are edited just like any other button, as described in the Editing Buttons section.

Remote Mode

You can connect multiple Mastermind GTs together and have them operate in unison. Selecting a preset or pressing an Instant Access button on any controller will cause the other controllers to switch similarly. This is a great feature for both stage and studio - you can have multiple controllers at different locations on the stage, have an additional controller operated off-stage by a tech, or have controllers in both the studio and the control room.

Before enabling Remote Mode, all of your Mastermind GTs need to have the exact same settings. Use the process described in the Loading and Saving Settings to a USB Flash Drive section to transfer the data from one unit to another until all of your Mastermind GTs are up to date.

Next, to enable Remote Mode, you need to use the MIDI Settings Menu to turn on the Remote parameter on all of the Mastermind GTs you wish to link. Next, connect the **Remote In** jack of the first GT to the **MIDI Out** of the second GT, the **Remote In** of the second GT to the **MIDI Out** of the third one, and so on. The first Mastermind GT (the only one that doesn't have its **MIDI Out** jack connected to the **Remote In** of another GT) should have its **MIDI Out** jack connected to the rest of your rig.

You can use either the standard MIDI or XLR jacks (if available) for connecting your Mastermind GTs – both types of connector can be used interchangeably. Please note that phantom power is not passed from one Mastermind GT to another – each unit will need its own power supply.

When the Mastermind GTs are turned on, you'll notice one or two arrows in the bottom right corner of the main display on each unit. The first unit in the chain will have an arrow pointing to the right, the last unit in the chain will have an arrow pointing left and any units in the middle of the chain will have arrows pointing left and right. These arrows indicate that remote mode communication is active.

External MIDI Control

The Mastermind GT can also be controlled by an external MIDI device such as a computer, sequencer or other type of MIDI controller. To enable this feature, set the **MIDI Rx Ch** parameter in the MIDI Settings Menu to the desired MIDI channel. Any bank or Program Change messages received through the **Remote In** or **USB B** ports on this channel will cause a preset change on the Mastermind GT.

The bank and program numbers are interpreted differently based on some settings:

Setlist=None

In normal bank and preset mode (no setlist active), the bank MSB, LSB and program numbers are combined to create the desired preset number. The formula is:

$$(\text{Bank MSB} \times 16384) + (\text{Bank LSB} \times 128) + \text{PC number} = \text{preset number}$$

There are only 768 presets within the Mastermind GT, so only bank numbers 0 through 2 are valid. The Bank MSB should always be set to 0 (or not sent at all), and Bank LSB should be 0, 1 or 2.

Setlist active, Bank=Song On

If you are using a setlist, and the **Bank=Song** parameter (found in the MIDI Settings Menu) is turned **on**, the Bank MSB and Bank LSB are combined to select a song out of the current setlist. (0 = first song in setlist, 1 = second song in setlist, etc.) The number is calculated as follows:

$$(\text{Bank MSB} \times 128) + \text{Bank LSB} = \text{song number}$$

The PC number selects which preset within the song is selected (0 = first preset in song, 1 = second preset in song, etc.)

Setlist active, Bank=Song Off

If you are using a setlist, and the **Bank=Song** parameter (found in the MIDI Settings Menu) is turned **off**, the bank MSB, LSB and program numbers are combined to create the desired preset number. The formula used is the same as in the **Setlist=None** section above.

Upon receiving bank and program change messages, the Mastermind GT will find the first song that contains the resulting preset and will load that song and preset.

CC Link: Controlling buttons using incoming CC messages

It's also possible to control IA buttons using CC messages sent from a computer or other MIDI controller. Each IA button has a parameter "CC Link" that enables this feature. When you turn CC Link on, incoming CCs are compared against the first action in each button's action list. If the incoming CC matches the channel and CC number assigned to the first action in the action list, the button will update based on the CC's value (0-63 = off, 64-127 = on).

For example, if the first action on a button is "Device 1 / CC Toggle #14", and MIDI device 1 is set to channel 4, then incoming CCs on MIDI channel 4 with CC number 14 will control the button.

Please note that each device has an "Ignore Incoming CCs" setting, which when set, will disable the CC Link feature for that device.

When an IA button is activated, the button will execute all of its actions except the first one in the list (the CC that triggered the button in the first place). This helps to avoid endless loops between the GT and computer.

Remote Control

The "Remote Control" setting is typically used in conjunction with CC Link. When a button has Remote Control turned on, the button will not change state when you press the button, but it will send its messages. It will only change its state from an incoming CC message as described above under CC Link. This is intended for use with computer based systems where the computer sends status update messages to a connected controller to keep the buttons in sync with the actual state of program features.

Other Special Features

Global Preset

The global preset, if enabled, is an additional preset that can be accessed from any other preset simply by pressing the currently selected preset button again. This is typically used to set up a preset that is your “standard” or “go-to” guitar sound that’s always accessible, no matter what bank of presets you’re currently using.

To enable the global preset, enter Setup Mode and press the **Preset 2nd** (Preset 2nd Press) option. Set it to “Global”. Setting it to “Preset” disables the global preset feature.

There are also other settings for the **Preset 2nd** setting: “Previous”, which moves you back to the previously selected preset when you press the currently selected preset button a second time. “Same” keeps you on the same preset, basically having no effect at all. “Reload” also keeps you on the same preset, but will reload the current preset, resetting IA buttons and device preset selections to their saved values.

Page, Preset, Scene, Song and Setlist Menus

There are special button types called “Page Menu”, “Preset Menu”, “Scene Menu”, “Song Menu” and “Setlist Menu”. Pressing one of these buttons makes the entire Mastermind GT surface a selection menu, giving you quicker access to a specific page, preset, scene, song or setlist. If needed, **Prev** and **Next** buttons are displayed so you can scroll through the multiple pages of choices. Please refer to the Edit Button menu reference for more details on how to set a button to one of these types.

Preset Number Selection

There is also a “Preset Number” button type. Pressing it will allow you to type in a preset number and recall a preset directly. The Mastermind GT will automatically jump to the preset once you’ve typed in enough digits. For example: typing “001” will jump to the first preset. You can also press the Done button to jump to a preset without typing all the digits: “1”, “Done”.

On the Mastermind GT/10, there is not enough room to fit a Done button, so you’ll always need to type in the full preset number with leading zeros.

IA Linking

Sometimes, it’s useful to have one IA button turn on another. For example, you may have buttons on multiple button pages, each of which control the same effect. If you turn one on, you would want the others to turn on as well to reflect the current state of your effect. If you turn on reverb on button page 1, a reverb button on button page 2 should be on as well. This will work across all 16 button pages, including the current preset’s local button page if there is one.

To do this, turn on the “IA Link” parameter on each of the IA buttons. You also need to have the first action in each button’s list be identical. For our reverb example, each button would have to send the same CC message turning reverb on (or off) in order for the IA Link to work. The second and subsequent actions on each button don’t need to be the same for the IA Link to work.

Please note that only the IA button that’s actually been pressed will send its MIDI messages. The linked IA buttons will change their visible state to match the IA button that was pressed, but they will not send their messages.

Tap Tempo and MIDI Clock

The Mastermind GT supports MIDI clock as a master or slave. With MIDI clock, you can synchronize multiple devices to the same tempo. To enable MIDI clock support, go to the **MIDI Settings** menu. The **MIDI Clock** parameter can be set to “None” (the default), “Master”, “Slave” or “Auto”.

When set to "Master", the Mastermind GT will send a MIDI clock signal out the MIDI Out port, and optionally through the Remote In port, if the **MIDI Bidir** and **Clk->RemoteIn** are both turned on. The tempo will be adjusted any time a tap tempo button is used. Tempo can also be set on a per-song and per-preset basis. Each song and preset has a **Tempo** parameter. You can set the tempo for each song and preset there. If both the current song and preset have tempos specified, the preset's tempo is used – unless the **Ignore Preset Tempos** setting is activated.

There are special values that can be specified when editing preset or song tempos. These are described in the [Setup Mode Reference](#) section at the end of this manual.

When set to "Slave", the Mastermind GT will flash any tempo buttons in time with the incoming MIDI clock signal. It will also forward the MIDI clock signal to its other MIDI outputs. This allows the Mastermind GT to receive a MIDI clock signal from a computer via USB and forward it over standard MIDI connections to your other MIDI devices.

"Auto" is a special setting that acts like "Master" unless a clock signal is detected coming from the USB or Remote In. When a clock signal is detected, the Mastermind will act like the "Slave" setting and forward the incoming clock signal to the MIDI output.

Auto Tap

The Auto Tap feature allows the Mastermind GT to send MIDI messages automatically based on the current preset or song's tempo. When a preset is selected, MIDI messages are sent as if you were tapping the tempo button at the tempo indicated by the current preset or song.

There are two parameters that control this feature. Both are located in the top level setup menu. **Auto Taps** sets how many taps are generated (set to 0 to disable this feature). **Tap Macro** selects which macro is executed on each tap. The macro can send any MIDI message(s) you need. Typically, it would send CC messages to a pedal that's MIDI capable. When used with an external switcher like the Effect Gizmo or Amp Gizmo, you can also control pedals with an analog tap input. The Mastermind GT will send MIDI messages to the switcher and the switcher will send analog taps to the pedal.

Macros

Macros are predefined sequences of actions that you can reuse in multiple locations. Editing macros works just like editing the actions on a button – you can add actions to send different types of MIDI messages, change presets or button pages, etc. Macros are editing using the **Edit Macro** option in the setup menu.

To use a macro on a button, edit the button's action list. Add a System / Macro action to the button and select the macro you wish to run when the button turns on and when it turns off. You can use the same macro for both on and off, or you can have different macros for on and off states.

When running a macro, the state of the button is passed to the actions in the macro. For example, let's say you have a macro (we'll call it macro 1) defined as follows:

```
CC Toggle / Device 1, CC#80 off: 0 on:50  
CC Toggle / Device 1, CC#85 off: 0 on:27  
CC Toggle / Device 1, CC#90 off: 10 on:60
```

Next, you set up a button to call macro 1 when the button is turned on and also when the button is turned off. When you turn the button on, it will send the on values (CC80 = 50, CC85 = 27, CC90 = 60). When you turn the button off, it will send the off values (CC80 = 0, CC85=0, CC90=10).

You can force the macro to use one particular state or the other. To do this, edit the macro, and turn on the **Force State** parameter. Then, adjust the **Force State To** parameter to **On** or **Off** as desired. Then, the macro will always use selected state instead of using the button's state.

Loading and Saving Settings to a USB Flash Drive

The Mastermind GT allows you to load and save settings to a USB flash drive. You can use this feature to back up settings, transfer settings from one Mastermind GT to another GT, or to transfer settings to or from a computer.

The drive is plugged into the **USB A** port on the rear panel. Loading and saving are done from the System Menu. To get there, hold both soft buttons under the display. When the setup menu appears, select **System Functions**.

In the upper left corner of the menu, you will see the **Load Settings** and **Save Settings** options.

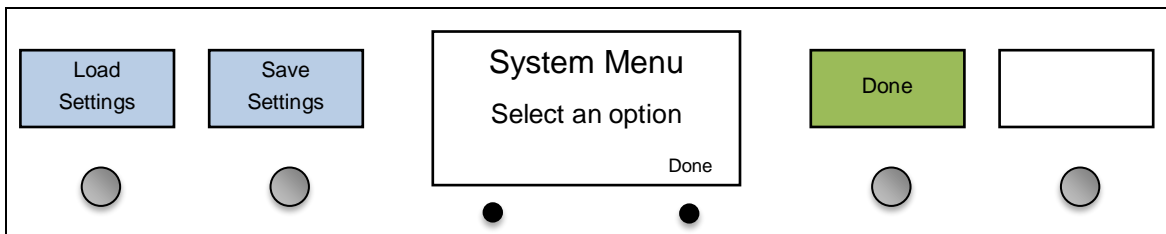

Load Settings

When **Load Settings** is selected, you are shown a list of the files that are on your flash drive. Only RJM settings files (ending in .rjs) and directories are visible. The **Move Up** and **Move Down** buttons move the selection bar up and down.

Selecting a directory with the right soft button views the contents of that directory, and selecting a file loads the settings in that file. You can press the left soft button at any time to cancel out of the load process and leave your settings unchanged.

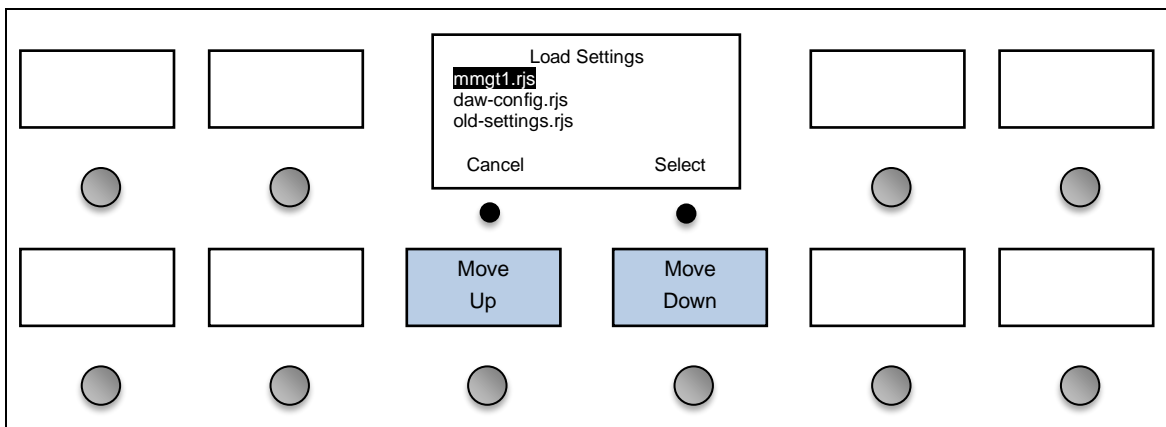

If the file loads without errors, your Mastermind GT will now be running with the new settings from the file.

Save Settings

Selecting **Save Settings** will bring up a menu that allows you to edit the filename you wish to give the settings. Edit the filename, then press **Done**. If a file of that same name exists, you will be asked if it's okay to overwrite the file. If you answer Yes (or if there is no pre-existing file to overwrite), the settings file will be saved to the top level directory of the flash drive.

Please note that all settings files need to end with ".rjs". You don't need to type this in, however. The system will add the extension for you if you don't type it in yourself.

Formatting

The flash drive needs to be formatted using the FAT (Windows) format with MBR partitioning. This can be done on a Windows PC, or on a Mac using the Disk Utility program. You can also format a flash drive using the GT itself by selecting the **Format Drive** option in the **System Functions** menu.

Connecting to a Computer

In addition to the USB flash drive support, the Mastermind GT's **USB B** port allows you to connect your controller to a PC or Mac with a USB port. The Mastermind GT is a class-compliant USB MIDI device, which means it doesn't need additional driver software. The Mastermind GT will appear as another MIDI device in your system and will work with any MIDI-enabled programs you're using.

To get the Mastermind GT to send commands over the USB port, use the Edit Devices menu to set the **MIDI Port** parameter to "USB". Any messages that are sent to that device will be sent over the USB port instead of the standard MIDI ports. Since you're communicating with a computer instead of an effect processor, you will most likely want to create a Generic MIDI device and set its MIDI port parameter to "USB". That will allow you to send commands to a computer without affecting the settings you have for your other MIDI devices.

The Mastermind GT has been tested successfully on PC systems running Windows 7 and Windows 8. Windows XP systems are not supported. Mac OS 10.7 through 10.9 systems are also known to be compatible with the Mastermind GT. Older Mac OS versions will likely work, but are not tested at this time.

Mastermind GT Editor

The Mastermind GT Editor software is available for free on our website. This software makes it even easier to edit your GT's parameters and back up settings to your computer. Settings can be transferred from the GT to the computer and vice versa using a USB flash drive or a direct USB connection from GT to computer.

Upgrading Firmware

The Mastermind GT is designed to be easily upgraded by the user. Firmware updates will be periodically made available on the RJM Music website. These updates will add support for more devices and add other new features.

The firmware upgrade process is simple: first, download the upgrade file from the RJM Music website using your PC or Mac. Copy the downloaded file to a USB flash drive. All RJM firmware files end in the extension “.rjf”, so it will be easy to tell which files are the ones you want. If there are any other .rjf files on the flash drive, delete them now. The Mastermind GT will load the first .rjf file it finds, so keeping only one firmware file on the drive at a time will make sure that the correct firmware is loaded.

Once the file is loaded to the flash drive, use the “Eject” option on the computer to safely remove the drive. On the Mac, this is done by pressing the eject arrow next to the drive’s name in the left column of the Finder. On the PC, go to “Computer” or “My Computer”, right click on the flash drive’s icon and select “Eject”. You can now remove the flash drive from the computer.

Start with the Mastermind GT powered down. Hold both of the small buttons under the main screen, and while still holding them, power up the Mastermind GT. Once you see text on the screen, you can release the buttons. Now plug the flash drive into the **USB A** port. The upgrade process will take a minute or two, then the Mastermind GT will start up. Once it’s in the normal operating mode (all the displays lit up and a song or preset name displayed), you can unplug the flash drive and begin using your upgraded GT.

Setup Mode Reference

Setup mode allows you to configure all aspects of the Mastermind GT, from the MIDI messages it sends to the way information is displayed on the screens.

To enter setup mode, press and hold the two soft buttons located under the main display. After about 2 seconds, the display will change, indicating you're in setup mode.

In Setup Mode, the footswitch buttons switch from their normal functions to become a menu for selecting setup options. The soft buttons under the main screen change function from screen to screen. The bottom row of the main display has small labels over each soft button to indicate the function of each button.

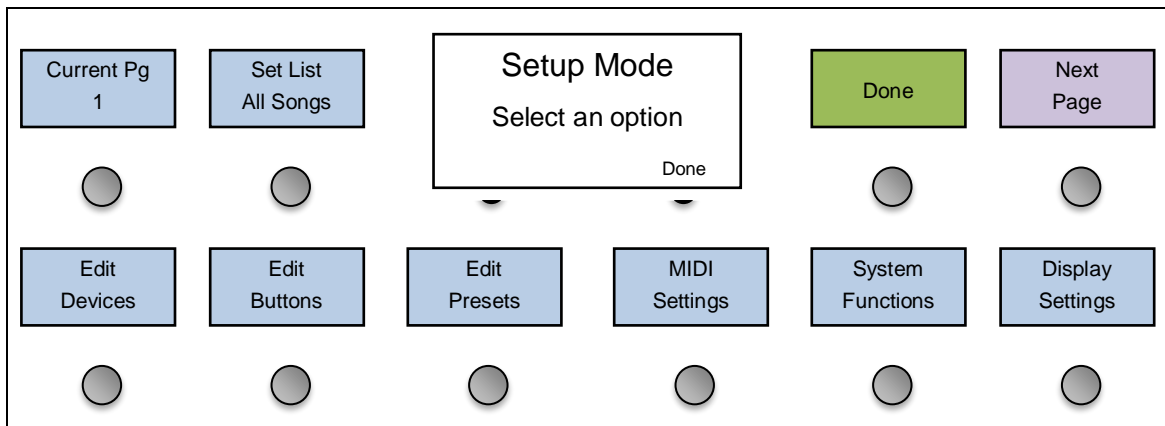

The button immediately to the right of the main display is always labeled **Done** (or **Cancel** when selecting a value from a list). This button will exit the current setup menu level and move up to the previous menu. Pressing **Done** in the top level setup menu will return you to the normal operational mode.

Each setup menu may have more available options than can be displayed on the Mastermind GT's displays. If this is the case, the **Next Page** button will be lit. Pressing this button cycles through all of the available options, one page at a time.

You can exit Setup Mode at any time by holding the left soft button and pressing the right soft button. This brings you directly to the normal operational mode of the Mastermind GT.

Button Selection

In certain menus, you will be asked to select a button. If this is the case, the footswitch buttons will show their normal functions except that they will flash to indicate that you're in setup mode. You can select any button on the currently visible page simply by pressing it. To switch to a different button page, press the left soft button (labeled **Next Page**).

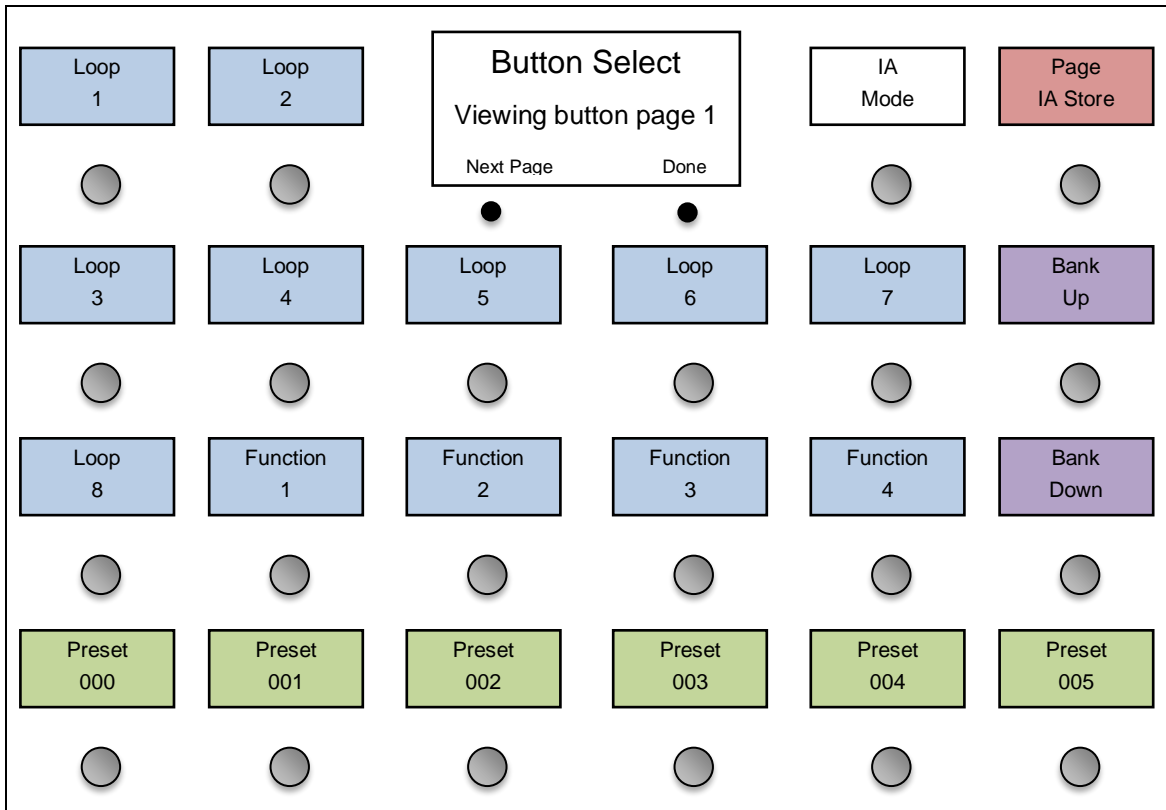

Text Entry (Mastermind GT/10 and Mastermind GT/16)

When editing names and other text, the Mastermind GT/10 and Mastermind GT/16 display the following menu:

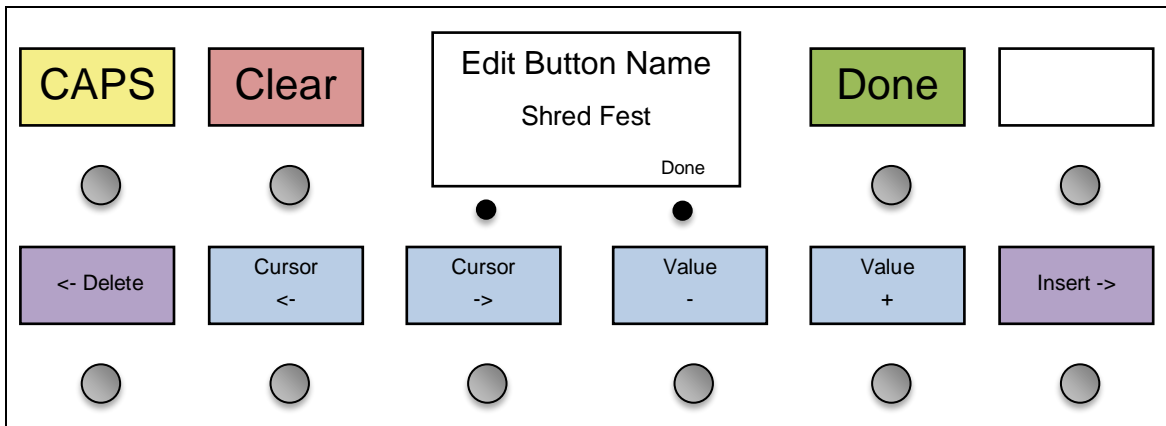

Text is edited by moving the cursor back and forth using the **Cursor <-** and **Cursor ->** buttons, then using the **Value -** and **Value +** buttons to change the value of the character under the cursor.

The **<- Delete** button will delete the character to the left of the cursor, and the **Insert ->** button will insert a space at the current cursor position.

Press **Done** when you've finished editing the text. The text will be saved and you'll be returned to the previous menu.

Number Entry (Mastermind GT/10 and Mastermind GT/16)

When editing numbers, the Mastermind GT/10 and Mastermind GT/16 display the following menu:

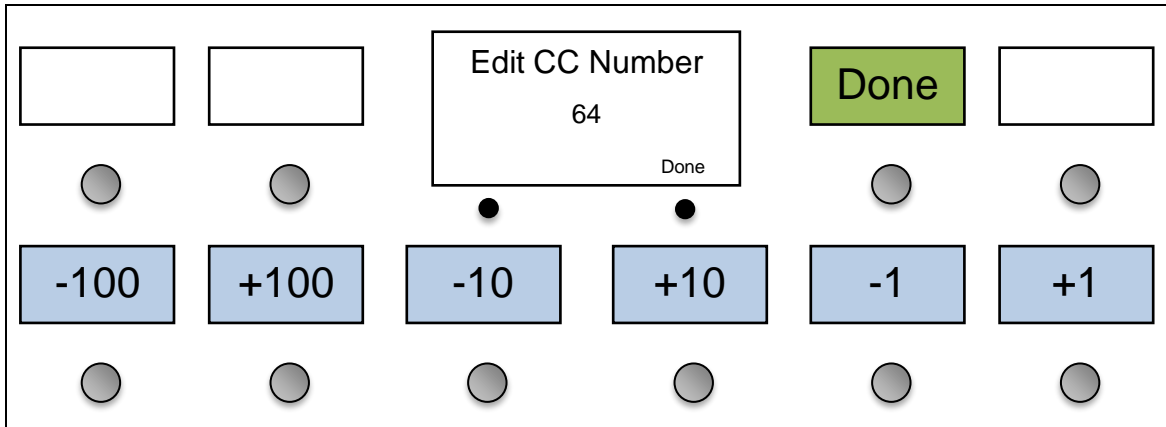

You can adjust the number using the minus / plus value buttons in the bottom row.

Press **Done** when you've finished editing the number. The number will be saved and you'll be returned to the previous menu.

Text and Number Entry (Mastermind GT/22)

When editing names and certain other parameters, the Mastermind GT/22 uses the footswitches as a keyboard to allow you to type in letters and numbers.

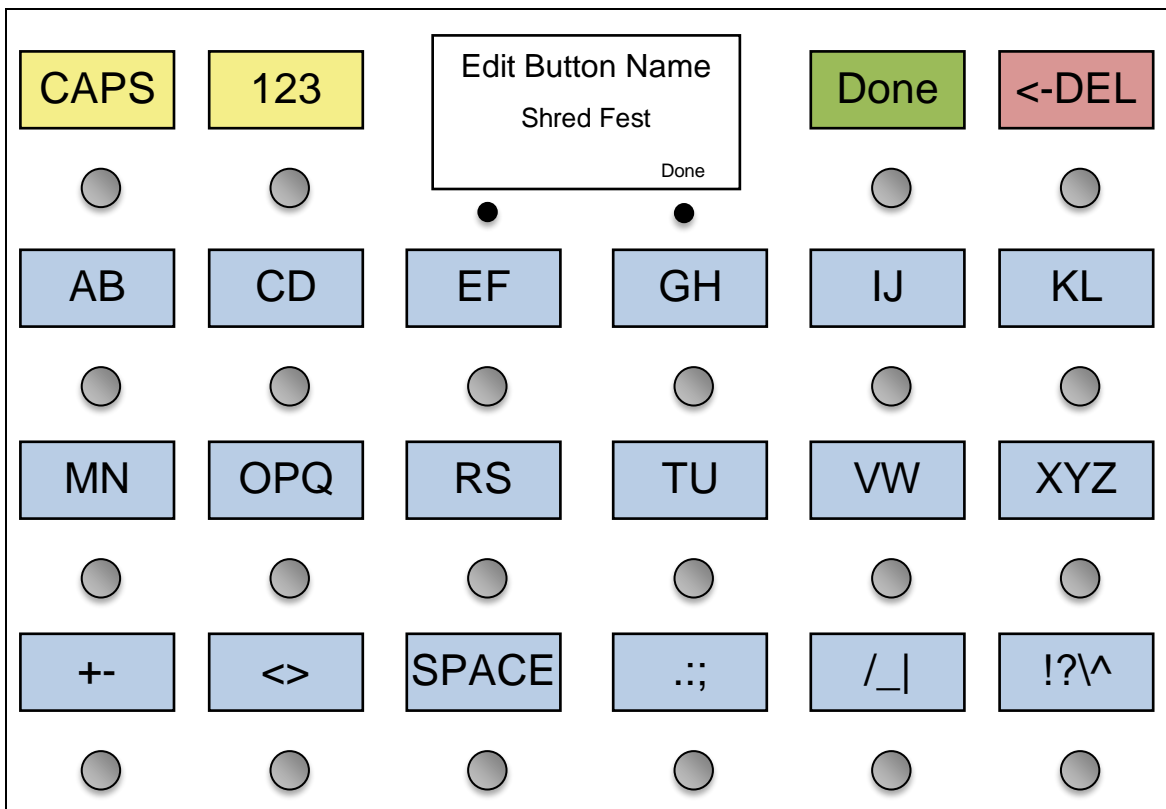

The letters are placed in groups of two or three. Pressing a letter button will select the first (leftmost) letter, and pressing the button again quickly will move to the next letter. For example, pressing the **OPQ** button once will place an "O" on the screen. Pressing it again quickly will change the "O" to a "P". Pressing it a third time will change the "P" to a "Q". If you press another letter or wait about 1.5 seconds, the letter will be accepted and you will move to the next letter position.

CAPS – changes the letter buttons from upper to lowercase, allowing you to type lower case letters. Pressing it a second time will switch back from lower to upper case.

ABC / 123 – switches the lower buttons to show either letters or numbers and symbols.

<-DEL – Deletes the last character.

Done – Saves the current value and exits to the previous menu.

Note: If the parameter you are editing is a number, you will see fewer options – it won't let you enter letters or symbols.

Special Characters

When editing a button name, there are two characters that have special functions. The backslash (\) character inserts a line break. Any characters after a backslash will appear on the second line of text. The caret (^) character does the same, but also inverts the second line, so it shows colored text on a black background.

Only the first special character in a button title is processed – subsequent ones are ignored.

Special Values

When editing numerical values, there are sometimes special values that can be chosen. For example, this is the case when editing Page and Preset actions. You can type in a page or preset number, or you can press the **Special** button. Pressing that button will allow you to choose special values from a list. For Page and Preset buttons, the special values are **Up**, **Down** and **Previous**. For Preset actions, there's also a **Global** value. When you select one of these values, the preset or page number will not be set to a specific number, but instead will perform a specific function: move up one, move down one, go to the previously selected, or go to the global preset.

Main Menu

The first menu you see upon entering Setup Mode allows you to configure some system options as well as access submenus to edit devices, buttons and presets.

Current Pg. – Sets the currently visible button page. This is useful if you accidentally find yourself on a page that doesn't have a Page Select button defined.

Set List – Pressing this button allows you to select which setlist is active, and enables Song and Setlist Mode. When set to "All Songs", all 1008 songs will be used as your setlist. When set to "None", the controller displays your presets normally: by preset number and bank.

Edit Devices – Brings up the [Edit Devices](#) menu.

Edit Buttons – Brings up the [Edit Buttons](#) menu.

Edit Pages – Brings up the [Edit Pages](#) menu.

Edit Presets – Brings up the [Edit Presets](#) menu.

MIDI Settings – Brings up the [MIDI Settings](#) menu.

System Functions – Brings up the [System Functions](#) menu.

Display Settings – Brings you to the [Display Settings](#) menu.

Edit Songs – Brings up the Edit Songs menu. This menu is described in the [Song and Setlist Mode](#) section.

Edit Setlists – Brings up the Edit Setlists menu. This menu is described in the [Song and Setlist Mode](#) section.

Edit Groups – Brings you to the [Edit Groups](#) menu.

Exp Pedals – Brings up the [Expression Pedals](#) menu.

ExpPdl Blocks – Brings up the [Expression Pedal Blocks](#) menu.

Copy Button – This button allows you to copy one button to another location. You will first be asked to select which button you wish to copy, then where you wish to put the button. The new button will be an exact copy of the first button, performing exactly the same functions.

Swap Buttons – This button allows you to swap the position of one button with another. You will be asked to select two buttons. After the second button is selected, the two buttons' positions will be swapped.

Max Page – Sets the maximum page button page that will be visible. There can be up to 16 button pages, but it's best to limit the number of pages to those you actually need so that finding your page will be easier. When using a local preset button page, this page will always be visible, regardless of the Max Page setting.

Preset 2nd – Selects which action is taken when a preset button is pressed a second time. Setting this to "Same" (the default) stays on the same preset, having no effect. "Previous" causes the GT to switch back to the previously selected preset upon the second press of a preset button. "Global" causes the GT to switch to the global preset. (See the Global Preset section for details). "Reload" is like "Same", except that it reloads the current preset, resetting IA buttons and device PCs to the settings saved for the current preset.

Sysex Messages – Brings you to the [Sysex Messages](#) menu, which allows you to define Sysex messages that can be sent by buttons or presets.

Edit Macros – Brings you to the [Edit Macros](#) page, which allows you to define Macros, or sequences of button actions. These macros can be called by any buttons using the System / Macro action.

AltPrst Color – This setting allows you to choose which color is shown in your active Preset when its alternate preset is selected. See the Alternate Preset section for more details.

NP Color – With certain effect processors like the Fractal Audio Axe-Fx series, some IA buttons will be disabled or “Not Present” if the current preset does not include the effect that the IA button controls. This setting selects the color of a button that is not present in the preset. The default color is black (no backlight), but you can set this to any color you like.

StartLastPrst (start up on last preset) – Normally, when the Mastermind GT powers up, it will always start on preset 1 (or preset 0, depending on the “1st Preset is 0” setting). When StartLastPreset is turned on, the GT will start up on the last preset selected before it was powered down.

Startup Macro – chooses a Macro to be executed when the Mastermind GT starts up. This macro can send MIDI messages and/or perform system functions. When set to **None**, no macro will be executed on startup.

Auto Taps – Sets the number of times the auto tap macro is executed when the tempo changes. Refer to the [Other Special Features](#) section for more details on the Auto Tap feature.

AutoTap Macro – Sets which macro is executed by the auto tap feature. Refer to the [Other Special Features](#) section for more details on the Auto Tap feature.

Show Tempo – When turned on, the current tempo will be displayed in the main display for a second when the tempo changes.

CalcTmpoFlash – When working with devices that send tempo flashes messages over MIDI, turning this parameter on makes the GT calculate the system tempo from the incoming tempo flashes.

IgnPrstTempos – When turned on, any tempo values set in presets will be ignored. Only tempos in songs and actions will be processed

1st Prst is 0 – Determines the number of the first preset in the system, either 1 (the default) or 0. This can be used to adjust the Mastermind GT’s numbering scheme to match your effects processor. Please note that this parameter only changes the preset numbers, not the name, so the default names (Preset 001, Preset 002, ...) will not change. You can use the **Init Prst Names** option in the [System Functions](#) menu to reset the preset names using the current preset offset.

Hold mSec - Sets the number of milliseconds needed to activate a button’s secondary hold function. The default value is 1200 msec (1.2 seconds)

1st Rpt mSec – Sets the number of milliseconds needed before a button repeats the first time. This is used on buttons like Bank Up and Bank Down that repeat if you hold them down. The default value is 1500 msec (1.5 seconds).

Repeat mSec – Sets the number of milliseconds needed before a button repeats the second and subsequent times. The default value is 300 msec (0.3 seconds).

Auto Page – When this setting is turned on (the default), selecting a new preset will cause the button page to change. When turned off, the current button page will not change unless you press a Page button or execute a Page action.

Instant Bank – Instant Bank mode, when turned on, will automatically switch presets when you press the Bank Up or Bank Down buttons. Instead of flashing the preset buttons, asking you to select a preset in the new bank, the GT will switch banks and load the preset that appears on the currently selected preset button. For

example, if you are on preset 3, and there are 6 presets per bank, pressing bank up will automatically switch to preset 9.

Page Preview – Page Preview changes how bank selection works. When turned off, the visible button page does not change until you select a new preset. When Page Preview is turned on, the visible button page changes as you move up and down through the banks. The button page associated with the first preset in a bank is the one that will be displayed for that bank.

Display Settings Menu

The Display Settings menu allows you to adjust the brightness and contrast of the main display and the button displays. Repeatedly press the corresponding brightness and contrast – /+ buttons to decrease or increase the contrast of the displays.

In addition, there are a few other options that affect the displays:

Bold – when turned on, everything will be displayed in bold fonts. This makes the fonts more readable, but slightly reduces the amount of information that can be displayed on each screen.

Page Name – When turned on, the name of the current page is displayed at the top on the main display. If this parameter is turned off, or the current page does not have a name, the current preset and song are displayed normally.

RversMenus – When turned on, the Page, Preset, Setlist and Song Menus are displayed with the first items in the bottom row of the Mastermind GT. When turned off, the menus are displayed with the first items in the top row.

Scene Names – When turned on, the current scene name will be displayed in the lower row of the main display. Please note that scene names are only used when working with the Axe-Fx III. This option has no effect in Song and Setlist mode.

SongNmOnly (Song Name only) - When turned on, makes the song name take up the entire main display. When this setting is turned off, both the song name and current preset are shown in the main display.

System Functions Menu

The System Functions Menu allows you to configure low level parameters and do system maintenance.

Load Settings – Allows you to select a settings file from the currently attached USB flash drive and load it into the system.

Save Settings – Allows you to save the current settings to an attached USB flash drive.

Init Prst Names – Initializes all of the preset names in the system to their default names: "Preset 001", "Preset 002", etc. The numbering of these names starts with 0 or 1, depending on the "1st Prst is 0" settings, which can be set in the [main setup menu](#).

System Info – Displays the versions of the firmware currently installed on the system as well as the electronic serial number of the Mastermind GT.

Debug Log – Displays detailed error messages used to debug the system.

System Test – Used at the factory to verify that the Mastermind GT is working properly.

Update Button FW – Each row of buttons in the Mastermind GT has its own microprocessor. This option forces a download of firmware to these microprocessors. This is typically done automatically when needed, but on occasion tech support may request that you use this option.

Format Drive – Allows you to format a USB flash drive for use with the Mastermind GT.

Factory Reset – Erases the memory of the Mastermind GT and restores all settings to the factory defaults.

Edit Devices

The Edit Devices menu allows you to define which devices are connected to the Mastermind GT. The Mastermind GT contains a database of information about popular MIDI devices and can do a lot of the setup for you once you tell it what kind of devices are connected.

The first thing that is presented is a list of the available device slots. Each slot will either show a device name or "None". You can select any of these slots, which will take you to the device edit screen for that slot.

Once you have selected the device you wish to edit, you are taken to the Edit Device Menu.

Edit Device Menu

Type – Sets the type of device that is in this slot. The menu first prompts you for the device manufacturer, then the device model. If your device is not listed here, you can use the Generic setting, which will allow you to manually configure parameters.

Name – Allows you to edit the name shown for this device.

MIDI Ch – Sets the MIDI channel for this device. This number needs to be the same as the channel that is set on the device itself. Most MIDI devices have a setting titled "MIDI Channel" or "MIDI Receive Channel", and this is the parameter you need to change to match the setting here.

Assign Buttons - Brings you to the Assign Buttons, which allows you to assign this device's MIDI controller messages to buttons on the Mastermind GT. This button is not available when the device is set to "Generic".

Set Default Buttons – Sets up a page full of instant access buttons for this device. Once this button is pressed, you are asked which page number you wish to set up. The default buttons will be copied to this page, overwriting any IA buttons on the page. Other button types (Preset, Bank Up/Down, etc.) retain their original function, but will have a new instant access button underneath that can be accessed using IA mode. This button will not be visible when editing a device that doesn't support this feature.

Set Default Pedals – Sets the expression pedals to control common features on this device, typically wah and volume pedal functions. This button will not be visible when editing a device that doesn't support this feature.

Get Preset Names – Copies the names of all presets from the device to the Mastermind GT. This allows very quick setup of certain effect processors. This button will not be visible when editing a device that doesn't support this feature. By default, this feature will try to read the names of all 768 presets. You can press the **Stop** button to interrupt the process if you don't want or need to read the name of every preset. Please refer to the [Reading Preset Names](#) section for more details.

Direct Send – When this parameter is set to "Off", the GT will make attempts to reduce the number of MIDI messages sent. It will gather up CC and PC messages and eliminate duplicate messages. It will also sort CC messages into numerical order before sending. When this parameter is set to "On", the GT will send messages in the order requested by each action list, and it will not try to filter out duplicate messages.

Auto Names – Turning this setting on makes the Mastermind GT automatically read preset and bank names from the device in real time. With this option, you don't need to use the **Get Preset Names** feature. Currently, Auto Names is only available when using a Kemper Profiling Amp.

Sync Names – Turning this setting on makes the Mastermind GT update preset names from your device. This differs from other methods in that it works all the time, updating the stored preset name as you select each preset. This option is only available on certain devices.

Port – Press to select the MIDI port this device is connected to – either MIDI Out, Remote In or USB. Normal connections will use the “MIDI Out” selection. Use “USB” to communicate with a connected computer. “Remote In” allows communication through a bidirectional MIDI connection to the **Remote In** port. **MIDI Bidir** needs to be enabled in MIDI Settings for the **Remote In** port to be used as an output.

Preset Offst - Sets the starting preset number for a device. Effect processors typically start numbering their presets with number 0 or 1. Setting this number correctly will insure that the preset numbers on the Mastermind GT agree with those on the effect processor.

Max PC # - Sets the maximum program change number accepted by a device. MIDI specifies a maximum number of 127, but not all effect processors have that many presets. Setting this correctly insures that the Mastermind GT doesn't send a program change number that's too large. On devices that support MIDI banks, this determines how many presets are in each bank. This is typically set to 127, but some devices use a smaller bank size.

of Presets - Sets the total number of presets the device has.

Bank Type – Sets the type of MIDI bank message accepted by a device. MIDI bank messages are used to access more than 128 presets on a device. There are several ways this can be done, and the type of banks used will vary from device to device. The possible settings are: None (no bank support), LSB, MSB and MSB:LSB.

Flat Numbering – This setting controls how you specify presets and banks to devices that support MIDI banks. When checked, you can specify preset numbers for this device as a single preset number. When not checked, you select presets using a PC number and bank number.

Init PCs -None- – Initializes all presets for this device. Selecting this option will initialize all presets on the Mastermind GT to send no program change messages to this device. This is different than turning the **Send PC** setting off in that it can be overridden on any preset using the Edit Presets menu and assigning a PC number to this device for one or more presets.

Init PCs All 0 – Initializes all presets for this device. Selecting this option will initialize all presets on the Mastermind GT to send program change number 0 to this device.

Init PCs Sequential – Initializes all presets for this device. Selecting this option will initialize all presets on the Mastermind GT to send a sequential program change number to the device. Preset #0 will send program change #0, preset #1 will send program change #1, etc. This is the default setting for a new device.

CC On Prst (Send CC on Preset Change) – When set to “On”, this device will receive CC messages every time the preset changes, and when an IA button is pressed. When set to “Off”, this device will only receive its CC messages when an IA button is pressed.

Send PC – When set to “On”, the Mastermind GT will be allowed to send PC messages to the device. When set to “Off”, PC messages will not be allowed. Setting this to “Off” will disable some of the PC and Bank related items in the Edit Buttons menu.

SndRdunPC (Send Redundant PC) – When set to “Off”, the same PC message will never be sent to a device more than once in a row. Some effects processors will cause a gap or hiccup in the audio when receiving a PC message, so turning this parameter off will help prevent that from happening. Turning this parameter to “On” will cause the Mastermind GT to send a PC message when requested, whether it's a duplicate or not.

IgnorePCIn (Ignore Incoming PC) – When set to “On”, any incoming program changes generated by this device will be ignored. Otherwise, these incoming PC messages will cause the GT to change presets when received.

IgnoreCCIn (Ignore Incoming CC) – When set to “On”, any incoming continuous controller messages generated by this device will be ignored. Otherwise, these incoming CC messages (and other status messages) will cause the GT to change IA button states.

Delete Device – Deletes this device from the system, leaving an empty slot.

Assign Buttons

The Assign Buttons menu allows you to assign a device’s MIDI controllable functions to buttons on the Mastermind GT. There’s no need to dig through manuals to look up CC numbers anymore! You are first presented with a list of functions that are available on your MIDI device:

If the list of functions takes up more than one page, the **Next Page** button will be shown. These buttons will let you move between the pages of functions.

Once the function is selected, the menu will ask which button should receive the function. This is done using the Button Selection menu described earlier in this section. You will be asked if you wish to **Replace** or **Add** the function to the button.

Replace will delete the existing contents of the button, then copy the new function to the button. The button will be turned into an instant access button with the newly selected function assigned to it.

Add will add the newly selected function to the button, preserving the button’s type and list of existing functions. When pressed, the button will activate or deactivate all of the functions assigned to it. If the button is not an instant access button, this function will be placed “under” the button and will be revealed when Instant Access Mode is turned on.

Edit Buttons

The Edit Button menu allows you to edit each button’s type, name, color and the list of actions the button performs. The Edit Button menu first asks you which button you wish to edit using the Button Selection menu. Once a button is selected, The Edit Button menu is presented.

Mode – Sets the mode of the button, which can be “Normal” or “Hold”. If set to “Hold”, the button will have two completely different functions. The first function is what happens when a button is pressed. The second function is what happens when the button is held. If this parameter is set to “Normal”, the button only has one function, which is activated when the button is pressed.

Editing – This parameter is visible when the **Mode** parameter is set to “Hold”. Pressing this button toggles between “Normal” and “Hold” and indicates whether you’re editing the Normal or Hold function of the button.

Type – Selects the type of this button. The button types are as follows:

- **Bank Down** – selects the previous bank of presets
- **Bank Up** – selects the next bank of presets
- **Dev PC -** – Decrements the current program number of a specific device. This allows you to scroll through the list of presets on a specific device without affecting the other connected devices. The button will always display the device’s current PC number (and bank number if appropriate)
- **Dev PC +** – Increments the current program number of a specific device. This allows you to scroll through the list of presets on a specific device without affecting the other connected devices. The button will always display the device’s current PC number (and bank number if appropriate)

- **Get Preset Names** – Jumps you directly to the [Get Preset Names](#) menu, which allows you to read names from the selected device (if the device supports this feature)
- **IA** (instant access) – a general purpose button that can execute a list of button actions
- **IA Mode** – reveals the IA buttons “underneath” non-IA buttons
- **IA Store** – stores the current IA state and device PCs to the current preset
- **Label** – a button that has no function except to display text
- **Page/IA Store** – selects the next button page, or, when held for 2 seconds, stores the current IA state and device PCs to the current preset
- **Page Down** – displays the previous button page
- **Page Menu** – pops up a menu of all pages so you can quickly select one
- **Page Up** – displays the next button page
- **Preset** – preset selection button
- **Preset Menu** - pops up a menu of all presets so you can quickly select one
- **Preset Number** – pops up a number keypad, allowing you to directly type in a preset number
- **Preset +** - moves up one preset
- **Preset -** - moves down one preset
- **Prev Preset** – switches back to the last selected preset
- **Scene Menu** – pops up a menu of all available scenes for the current preset. This only applies when using an Axe-Fx III.
- **Song Menu** - pops up a menu of all songs so you can quickly select one
- **Setlist Menu** – pops up a menu of all setlists so you can quickly select one
- **Setup Mode** – activates setup mode

Global – Setting this parameter to “On” means that the button is global and will appear on every button page. Setting this parameter to “Off” means that this button only appears on the currently selected button page.

Name – Sets the name shown for this button when in normal mode (not IA mode).

IA Mode Only – *This parameter is only available when editing a button’s hold function.* When selected, this hold function is only active when the GT is in IA Mode.

Show Name – *This parameter is only available when editing a button’s hold function.* When selected, the hold function’s name will be shown in the bottom row of the button’s display. When turned off, the hold function’s name will never be displayed.

On Color – Sets the color of this button when the button is on and the controller is in normal mode.

Off Color – Sets the color of this button when the button is off and the controller is in normal mode. This option is not available when editing a Hold Function.

Both Color – Sets the color of this button when in normal mode and both the button’s normal function and the button’s hold function are on. This option is only available when editing a Hold Function.

Min Value, Max Value – These parameters are only available on Bank Up, Bank Down, Page Down, Page Up, Page / Store, Preset Up and Preset Down buttons. These parameters limits the range of banks, songs, pages or presets a button can access. For example, you might have 8 button pages defined, but you can set the Min Value and Max Value to 1 and 4 respectively. This will limit the page button(s) to scroll through only pages 1 through 4. If Min Value and Max Value are set to the same number, they are ignored and the buttons will scroll through all available songs, pages or presets. Please note that if the current button page has a local button page, that page will always be available using the Page buttons, regardless of the specified page limits.

IA Name – Sets the name shown for this button when in IA mode. This option is not available for IA buttons.

IA On Color – Sets the color of this button when the button is on and the controller is in IA mode. This option is not available for IA buttons

IA Off Color – Sets the color of this button when the button is off and the controller is in IA mode. This option is not available for IA buttons or when editing a Hold Function.

IA Both Color – Sets the color of this button when in IA mode and both the button's normal function and the button's hold function are on. This option is only available when editing a Hold Function.

Group – This allows IA buttons to be grouped, where only one button in the group is allowed to be on at a time. Pressing a button in the group turns that button on, and also turns all of the other buttons in the group off. This is typically used for things like amp channel selection, where the amp may have 3 or 4 channels but can only have one turned on at a time. There are 12 groups, and each group is independent of the others. All buttons with the same group number will be treated as the same group, regardless of which page the buttons are on.

Device – This parameter is only available on Device PC +/- buttons. It indicates which device the button should control.

Preset Index – This parameter is only available on preset buttons. It indicates the order in which preset buttons should be filled with the current bank's presets. Preset index 1 displays the first preset in the bank, preset index 2 displays the second preset in the bank, etc.

Gaps in the preset indexes are skipped. If you number your preset buttons 1, 24 and 32, index 1 will show the first preset in the bank, index 24 will show the second preset in the bank and index 32 will show the third preset.

If two or more preset buttons have the same index (as in the default configuration), they will be given different preset numbers. For example, if you have 5 preset buttons, all with the same preset index, one will show the first preset, the next one will show the second preset, etc. When index numbers are the same, presets are assigned starting with the button in the upper left corner, and continuing from left to right, top to bottom, until the last preset button is assigned.

Button Actions (x) – This button displays the number of Actions it currently has assigned to it. Pressing the button brings up the list of Actions that are assigned to this button. Each button may have up to 20 Actions assigned to it. Each action is typically a continuous controller message sent to control a function on a device, but it could also be another type of MIDI message or a system action that controls the Mastermind GT itself.

In the Button Actions menu, pressing one of the Action buttons or the Add Action button brings up the Action Edit menu.

IA Cycle – Turning this on makes this IA button cycle between multiple states. Instead of just having on and off states, the button can have up to four different states, and pressing the button will cycle through each state. See the [IA Cycle](#) section for more details.

Cycle Menu – Turning this on makes the button pop up a menu of all cycle steps when pressed. **IA Cycle** must be turned on for this option to be available. See the [IA Cycle](#) section for more details.

CC Link – When this parameter is turned on, it allows this button to be controlled by incoming CC messages. Please see the [External MIDI Control](#) section of this manual for more information.

Remote Ctrl – When turned on, pressing the button will execute the button's actions, but will not change the state of the button. Only an incoming CC message will change the button's state. This setting is used in conjunction with CC Link and allows bidirectional control of features in DAW software. Please see the [External MIDI Control](#) section of this manual for more information.

IA Link – When this parameter is turned on, this button will be linked to other IA buttons that have the same first action in their action list. Turning one IA button on will turn all other linked buttons on, turning one IA button off will turn the linked buttons off. Please refer to the [IA Linking](#) section for more details.

SndOnPrst (Send on preset change) – When set to “On”, this button will send its messages every time the preset changes. When set to “Off”, this button will only send its messages when it is pressed.

UpdOnPrst (Update on preset change) – When set to “Off”, this button only changes state when it receives a MIDI message from the device it is associated with, or when the button is pressed. When set to “On”, the button can also change state when a new preset is selected. Typically, this is always turned on, but with certain devices like the Axe-Fx it should be turned off.

Tempo – When set to “On”, this button is marked as a tap tempo button. These buttons flash with the currently set tempo. If **UpdOnPrst** is also turned on, this button will flash in time with the internal tempo clock. If **UpdOnPrst** is turned off, this button will only flash when instructed by the connected device.

Show Tempo – When set to “On”, this button will display the current tempo value. This is only available when **Tempo** is turned on.

Momentary – When set to “On”, this button is momentary – it turns on when pressed and turns off when released. When set to “Off”, this button is a normal (push on / push off) button.

OnMsgOnly - When set to “On”, this button will only send messages when it is turned on by a preset. When a preset turns this button off, this button will not send any messages. This setting does not affect what happens when the user actually presses the button.

Step [1..4] Name - When **IA Cycle** is turned on, these parameters set the name that will be shown for each of the four steps the button can cycle through.

Step [1..4] Color - When **IA Cycle** is turned on, these parameters set the color that will be shown for each of the four steps the button can cycle through.

Action Edit

The Action Edit screen allows you to edit the details of an action assigned to a button. These actions are performed when an instant access button is pressed. An action can be a MIDI message that is sent, or something that affects the system (change to a new button page, etc.)

Type – Sets the type of this action. Possible values are: CC Toggle, CC Momen (Momentary), PC (Program Change), Note, Sysex and System.

Delete Action – Deletes this action from the button it was assigned to.

Device – Brings up the Device Select screen to allow you to select which device this action should be performed on. When **Type** is set to System, this item is not displayed, and **Function** is shown instead

Function - Allows you to select the system function when editing a System action. See System type, below.

The next three buttons change their function based on the setting of the **Type** parameter:

CC Toggle or CC Momentary

CC Number – Sets the continuous controller number for the action

On Value – Sets the continuous controller value that is sent when the button is turned on

Off Value – Sets the continuous controller value that is sent when the button is turned off

PC (Program Change)

PC On – Sets the program number to be sent with the button is turned on

PC Off – Sets the program number to be send when the button is turned off

The last of the three buttons is not active when editing a Program Change action.

Note

Note – Sets the note number for the action

Velocity – Sets the note velocity for this action

The last of the three buttons is not active when editing a Note action.

Sysex

Sysex actions send one of the possible 127 Sysex messages that can be defined by the user. These messages are defined using the Sysex Messages menu.

Off Msg – selects which Sysex message is sent when the IA button is turned off.

On Msg – selects which Sysex message is send when the IA button is turned on.

System

System actions are further defined by the **Function** parameter. The possible settings for Function, and their parameters are as follows:

BPM

The BPM action allows you to set the current tempo when a button is turned on or off. Any tempo between 1 and 400 PBM can be specified, with one decimal place. Pressing the **Special** button allows you to select from a list of special values: "None" (turn off tempo clock), "Preset" (use the current preset's tempo), "Song" (use the current song's tempo), "Same" (keep the same tempo), "Plus 1", "Minus 1", "Plus 0.1", "Minus 0.1" (adjust the tempo by the specified amount).

Exp Pedal

The ExpPedal action allows you to select one of the 128 expression pedal settings blocks when a button is turned on or off. This allows you to change your expression pedal settings on the fly. Pressing the **Special** button allows you to select from a list of special values: "Global" (return to this pedal's global setting), "Preset" (return this pedal's override settings specified in the current preset).

IA Mode

The IA Mode function allows you to turn IA mode on or off. This performs the same function as the IA Mode button, but because this is a button action and not a button type, it can be combined with other actions on the same button.

IA Store

Stores the current state of every IA button and all device PCs to the current preset.

Macro

The Macro function allows you to run one of the 128 macros defined in the system. Please see the [Macros](#) section for more information.

Page

The Page function makes the Mastermind GT switch to a particular button page when this button is pressed.

Page # - Selects the page number that should become visible when this button is pressed. When editing the page number, you can press the **Special** button to select special functions: "Up" (move up one page), "Down" (move down one page) and "Prev" (move to previously selected page).

Preset

The Preset function recalls a particular preset when this button is pressed.

Preset – which preset to recall when this button is turned on. When editing the preset number, you can press the **Special** button to select special functions: "Alternate" (select this preset's alternate preset), "Up" (move up one preset), "Down" (move down one preset), "Prev" (move to previously selected preset), "Global" (select global preset) and "Same" (stay on the same preset).

Setlist

The Setlist function allows you to select a specific setlist when the button is turned on or off. You can choose any of the 64 setlists. You can also press the **Special** button to select special functions: "Up" (move up one setlist), "Down" (move down one setlist), "All Songs" (move to the "All Songs" setlist), "None" (return to bank and preset mode) and "Same" (stay on the same setlist).

Song

The Song function allows you to select a specific song when the button is turned on or off. You can choose any of the 1008 songs. You can also press the **Special** button to select special functions: "Up" (move up one song), "Down" (move down one song), "Prev" (go to the previously selected song) and "Same" (stay on the same song).

Step

This defines the end of a step for a cycle button. Please refer to the [Cycle Buttons](#) section for more details.

Tuner

The Tuner function turns on the tuner display when this button is selected. This allows you to display tuner information from a connected device that sends tuner information over MIDI.

Assign CC – This button allows you to choose a continuous controller from the list of functions defined for each device. When this button is selected, you are prompted for a device, then prompted for one of the functions available on the device (if any). The continuous controller number associated with that function is copied to this action.

Edit Pages

The Edit Pages menu lets you set parameters that are specific to each button page.

Name – Allows you to name each button page. This name will be displayed briefly when switching pages and in the Page Menu. If **ShowPageNames** is turned on in the [Display Settings](#) menu, the page name will also be displayed at the top of the main screen if the page name is not blank.

Edit Presets

The Edit Presets menu lets you define which program change messages are sent to each device for the preset, as well as the preset name, expression pedal settings and the current button page.

Name – Sets the name of this preset.

Page – Sets the number of the button page that will be displayed when this preset is selected. Setting the page to "Same" will keep the current button page when the preset is selected.

Alt Preset – Each preset can have an alternate preset defined using this setting. The alternate preset can be accessed by a second press on a preset button (see the Preset 2nd Press setting), or using a System / Preset Action.

Tempo – Sets the tempo (in BPM) for this preset. A tempo setting of **0** (zero) indicates that this preset has no tempo defined. See the [Tap Tempo and MIDI Clock](#) section for details.

Auto Tap Div – Sets the tempo division for the Auto Tap feature. This allows you to alter the tempo sent to other devices controlled by the Auto Tap feature. Possible values are "Qtr" (quarter note), "Dot8th" (dotted eighth)", "QtrTrip" (quarter note triplet), "8th" (eighth note), "8th Trip" (eighth note triplet) and "16th" (sixteenth note).

MIDI Clock Div – Sets the tempo division for the MIDI Clock output. This allows you to alter the tempo sent to other devices controlled by MIDI clock. Possible values are "Qtr" (quarter note), "Dot8th" (dotted eighth)", "QtrTrip" (quarter note triplet), "8th" (eighth note), "8th Trip" (eighth note triplet) and "16th" (sixteenth note).

Btn Color – Allows you to select a specific color for this preset when its preset button is selected. By default, this is set to "None", which means use the preset button's On color.

Exp Pedals – Brings you to the Expression Pedals menu to allow you to override the global expression pedal settings for this preset.

External Switches – Brings you to the External Switches menu to allow you to override the global external switch settings for this preset.

Local Buttons – Turning this on enables this preset to have a local button page. This button page will automatically be displayed when the preset is selected, and will take the place of button page 16.

Edit Buttons – When **Local Buttons** is turned on, this option will become visible, allowing you to edit the local button page for this preset.

Edit Page Name – When **Local Buttons** is turned on, this option will become visible, allowing you to edit the local button page's name.

Preset Actions (x) – This button allows you to edit the actions that are assigned to this preset. Pressing this button brings up a list of actions assigned to this preset, and an Add Action button. Pressing any of those buttons will bring you to the Edit Action screen, described above.

Scene Names – Pops up a submenu that allows you to edit the scene names for the current preset. Scene names are only used when controlling an Axe-Fx III.

Copy Preset – Allows you to copy the current preset to a new location.

The remaining buttons show any devices that are defined, and the bank and preset number that will be sent to those devices when the preset is selected. Pressing one of these buttons allows you to change the bank and PC number for the associated device. On the Axe-Fx III, you can select a scene number as well.

Expression Pedals

The Expression Pedal menu allows you to edit the behavior of any of the four expression pedals. This menu can be accessed from the Main Menu, which is where you set the global expression pedal settings. These same parameters are editable for each of the 128 expression pedal blocks, also accessible from the main menu. You can also enter this menu from Edit Presets, which allows you to override the global settings for a preset.

Override – This parameter is only visible when editing the expression pedal settings for a particular preset (not from the Main Menu). When editing a preset, turn this parameter **On** to override the global settings for this expression pedal. The remainder of the settings below will be displayed so you can edit the expression pedal settings for the current preset.

Name – Allows you to name this expression pedal.

Switch Grp – Assigns the pedal's switch function to a button group. Setting this to a setting other than "None" will allow the pedal to interact with other buttons in a group, switching off other buttons in the group when the pedal switch is activated. See "Set Switch Position" below for more information on the pedal switch feature. Also see the Edit Buttons section for more information on button groups.

Calibrate – Enters pedal calibration. You are asked to move the pedal all the way up and all the way down. This insures that the pedal will work optimally with the Mastermind GT. Press the **Done** soft button when you are finished. This parameter is only available when editing the global pedal parameters from the Main Menu.

SndOnPrst – Turning this on makes the expression pedal send its current CC value(s) every time you change to a new preset. This parameter is only available in the global expression pedal menu.

Device – Selects the device this pedal will control. Uses the Device Select Menu to allow you to choose from the defined devices.

CC Number – Allows you to edit the continuous controller number sent by this pedal.

Min Val – Sets the value sent by the expression pedal when the pedal is raised up all the way.

Max Val – Sets the value sent by the expression pedal when the pedal is pushed all the way down.

Assign Pedal CC – This button allows you to choose a continuous controller from the list of functions defined for each device. When this button is selected, you are prompted for one of the functions available on the device. The continuous controller number associated with that function is to the CC Number parameter, and default values are filled in for Min Val and Max Val.

Device 2, CC Num. 2, Min Val 2, Max Val 2 and Assign Pedal CC 2 – These parameters allow you to set up the expression pedal to control a second CC parameter at the same time as it controls the first CC. This is particularly useful for cross-fading, where one parameter decreases while the another parameter increases (and vice-versa).

Set Switch Position – Saves the current pedal position as the switch point. When the pedal goes below the switch point, any defined actions in the Switch Action list will be turned off. When the pedal goes above the switch point, any defined actions will be turned on.

Switch Actions – Brings up the list of Actions assigned to the pedal position switch. These actions are triggered when the pedal moves above or below the switch position (defined using the **Switch Position** option). Each pedal may have up to 8 actions assigned to it. Each Action is typically a continuous controller

message sent to control a function on a device, but it could also be another type of MIDI message or a system action that controls the Mastermind GT itself.

Pressing one of the Action buttons or the **Add Action** button brings up the Action Edit screen, which allows you to choose an action and edit its parameters.

Invert Switch – When checked, inverts the sense of the position switch so that the switch is considered “off” when between the switch position and the toe down position, and “on” when between the switch position and heel down.

IA Link – When checked, links the position switch with other IA buttons that control the same function. See the [IA Linking](#) section for more details.

Edit Groups

The Edit Groups screen allows you to set some options for each of the button groups. Button groups allow you to set up your buttons so that only one button in a group is allowed to be turned on at a time. Activating one button will turn off the other buttons in this group.

Name – Allows you to set a name for this group for reference purposes.

SndOffMsg (Send Off Message) – When set to “On”, any button in the group will send its message(s) when turned on and when it’s turned off. When set to “Off”, a button will send its message(s) only when it is turned on, and never when it is turned off.

Allow Off – When set to “On”, it is possible to turn off all buttons in the group. Pressing a button that’s already selected will turn it off. When set to “Off”, one button in the group will always be turned on. Pressing a button that’s already selected will have no effect.

Group Actions – Each group can have its own actions. These actions only work when **Allow Off** is turned on. When all buttons in the group are turned off, the actions are executed using their Off values. When any button in the group is turned on, the actions are executed using their On values.

MIDI Settings Menu

MIDI Rx Ch – Sets the MIDI channel that the Mastermind GT will listen to. Any program and/or bank changes received on this channel will cause the Mastermind GT to jump to the selected preset and send all of the MIDI messages corresponding to that preset. This parameter defaults to “None”, which means that the Mastermind GT will not respond to incoming bank or program change messages.

Bank=Song – This setting affects what MIDI bank and Program Change messages do in Song And Setlist Mode. Please refer to the [External MIDI Control](#) section for more details.

MIDI Bidir – Turns bidirectional MIDI support on or off for the 7-pin DIN MIDI ports. Certain devices support bidirectional communication between the device and MIDI controller. This allows you to have two-way communication with a single 5 pin or 7 pin MIDI cable. Don’t turn this parameter on unless you know your device does support bidirectional MIDI. Bidirectional MIDI only works with the first device in your MIDI chain.

Remote – Turning this on enables remote mode. This allows more than one Mastermind GT to be connected together and have them all synchronized together. Refer to the [Remote Mode](#) section for more information.

MIDI Forward – When set to “On”, all MIDI messages that are received through the **USB B** port are sent to the **MIDI Out** port, and messages that are received through the **Remote In** port are sent to the **USB B** Port. This allows you to use the Mastermind GT as a MIDI interface for a PC.

MIDI Merge – When set to “On”, all MIDI messages that are received through the **Remote In** or **USB B** ports are retransmitted through the **MIDI Out** port. This setting is only available if **MIDI Forward** is turned off.

MIDI Clock – Determines whether the Mastermind GT acts as a MIDI clock “Master” or “Slave”. Setting this parameter to “None” (the default) disables MIDI clock support and setting it to “Auto” makes the Mastermind switch between Master and Slave modes based on whether a MIDI clock signal is detected. See the [Tap Tempo and MIDI Clock](#) section for more details.

Sysex Messages Menu

The Mastermind GT allows you to define 128 Sysex (System Exclusive) messages, which can be sent by any IA button or preset. These messages can be up to 16 bytes in length, and can contain any valid MIDI data.

When you select the Sysex Messages menu, you will be shown a list of all Sysex messages. Select one to begin editing. The message can be given a name with the Name option. Then, use the Add Byte option to enter the first byte in the message. Each byte of data is specified in hexadecimal, where digits are in the range 0-9 and A-F. You can add up to 16 bytes to a message. Selecting an already defined byte allows you to edit or delete the byte.

Edit Macros Menu

The Mastermind GT allows you to define 128 macros. A macro is a sequence of up to 32 actions that can be called by any IA button or preset. This allows you to reuse a sequence of actions in multiple locations, or to have more actions on a button than is normally possible. Please refer to the [Macros](#) section for more details.

When you select the Edit Macros menu, you will be shown a list of all macros. Select one to begin editing. Each macro allows you to edit the following:

Name – Allows you to edit the macro’s name

Force State – Allows you to use a specific state (on or off) when running the macro, instead of using the state of the button or switch that’s calling the macro.

Force To – Determines which state (on or off) should be used when running the macro. This parameter is only visible if **Force State** is turned on.

Macro Actions – Press this to edit the list of actions for this macro. The editing process is the same as described in the [Action Edit](#) section.

Specifications

Dimensions	GT/10: 19.4 (W) x 8.1 (D) x 3.25 (H) inches / 49.3 x 20.6 x 8.3 cm GT/16: 19.4 (W) x 11.1 (D) x 3.25 (H) inches / 49.3 x 28.2 x 8.3 cm GT/22: 19.4 (W) x 14.1 (D) x 3.25 (H) inches / 49.3 x 35.8 x 8.3 cm
Weight	GT/10: 6 lbs / 2.7 kg GT/16: 8 lbs / 3.6 kg GT/22: 10 lbs / 4.5 kg
Power	GT/10: 12V DC @ 700mA GT/16: 12V DC @ 1000mA GT/22: 12V DC @ 1500mA 5.5mm OD, 2.1mm ID x 9.5mm barrel connector (<i>BOSS-style</i>)
Phantom Power	Accepted over pins 6 and 7 of the MIDI Out jack, same specs as above GT/22 only: Accepted over pins 1 and 2 of the XLR MIDI Out jack, same specs as above Do not connect phantom power at the same time as the AC adaptor! Do not use pins 1 and 3 for phantom power!
Accessory Power Outputs	2x 9V DC @ 100mA (total current for both jacks) 5.5mm OD, 2.1mm ID x 9.5mm barrel connector, center negative (<i>BOSS-style</i>)

XLR MIDI Connectors (Mastermind GT/22 only)

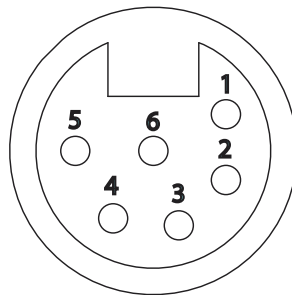

The XLR MIDI Out connector is a male 6-pin XLR connector, and the XLR Remote In connector is a female 6-pin XLR connector. These connectors carry MIDI data in both directions as well as phantom power to the controller. These connectors are wired in parallel with the standard DIN MIDI jacks, so it is very important to only use one of the two sets of connectors at a time.

The pinout is as follows:

Pin Number	XLR MIDI Out	XLR Remote In
1	Phantom power in (either polarity ok)	Not connected
2	Phantom power in (either polarity ok)	Not connected
3	MIDI input + (to GT)	MIDI output + (from GT)
4	MIDI input - (to GT)	MIDI output - (from GT)
5	MIDI output + (from GT)	MIDI input + (to GT)

6	MIDI output - (from GT)	MIDI input - (to GT)
---	-------------------------	----------------------

The "+" pins correspond to pin 4 and the "-" pins correspond to pin 5 on a standard MIDI connector.

The recommended mating connectors are Neutrik part number NC6MXX for the XLR Remote in and NC6FXX for the XLR MIDI Out.

Mastermind GT MIDI Implementation Chart

MIDI Implementation Chart v 2.0 (Page 1 of 3)			
Manufacturer: RJM Music Technology, Inc. Model: Mastermind GT Version: 3 Date: September 11, 2018			
	Transmit/Export	Recognize/Import	Remarks
1. Basic Information			
MIDI Channels	1-16	1-16	Channel 1 is set by default
Note Numbers	Yes	No	
Program change	Yes	Yes	
Bank Select Response? (Yes/No)	Yes	Yes	Sends any bank number
If yes, list banks utilized in remarks column			Uses bank MSB and LSB, banks 0-2
Modes supported :	Mode 1: Omni-On, Poly (Yes/No)	No	No
	Mode 2: Omni-On, Mono (Yes/No)	No	No
	Mode 3: Omni-Off, Poly (Yes/No)	Yes	Yes
	Mode 4: Omni-Off, Mono (Yes/No)	Yes	Yes
	Multi Mode (Yes/No)	No	No
Note-On Velocity (Yes/No)	Yes	No	
Note-Off Velocity (Yes/No)	Yes	No	
Channel Aftertouch (Yes/No)	No	No	
Poly (Key) Aftertouch (Yes/No)	No	No	
Pitch Bend (Yes/No)	No	No	
Active Sensing (Yes/No)	No	No	
System Reset (Yes/No)	No	No	
Tune Request (Yes/No)	No	No	
Universal System Exclusive:	Sample Dump Standard (Yes/No)	No	No
	Device Inquiry (Yes/No)	No	No
	File Dump (Yes/No)	No	No
	MIDI Tuning (Yes/No)	No	No
	Master Volume (Yes/No)	No	No
	Master Balance (Yes/No)	No	No
	Notation Information (Yes/No)	No	No
	Turn GM1 System On (Yes/No)	No	No
	Turn GM2 System On (Yes/No)	No	No
	Turn GM System Off (Yes/No)	No	No
	DLS-1 (Yes/No)	No	No
	File Reference (Yes/No)	No	No
	Controller Destination (Yes/No)	No	No
	Key-based Instrument Ctrl (Yes/No)	No	No
	Master Fine/Coarse Tune (Yes/No)	No	No
Other Universal System Exclusive	No	No	
Manufacturer or Non-Commercial System Exclusive	Yes	Yes	RJM Music Technology, Inc. Manuf. ID: 00 01 5B
NRPNs (Yes/No)	No	No	
RPN 00 (Pitch Bend Sensitivity) (Yes/No)	No	No	
RPN 01 (Channel Fine Tune) (Yes/No)	No	No	
RPN 02 (Channel Coarse Tune) (Yes/No)	No	No	
RPN 03 (Tuning Program Select) (Yes/No)	No	No	
RPN 04 (Tuning Bank Select) (Yes/No)	No	No	
RPN 05 (Modulation Depth Range) (Yes/No)	No	No	
2. MIDI Timing and Synchronization			
MIDI Clock (Yes/No)	No	No	
Song Position Pointer (Yes/No)	No	No	
Song Select (Yes/No)		No	
Start (Yes/No)	No	No	
Continue (Yes/No)	No	No	
Stop (Yes/No)	No	No	
MIDI Time Code (Yes/No)	No	No	
MIDI Machine Control (Yes/No)	No	No	
MIDI Show Control (Yes/No)	No	No	
If yes, MSC Level supported			
3. Extensions Compatibility			
General MIDI compatible? (Level(s)/No)	No	No	
Is GM default power-up mode? (Level/No)	No	No	
DLS compatible? (Levels(s)/No)	No	No	
(DLS File Type(s)/No)	No	No	
Standard MIDI Files (Type(s)/No)	No	No	
XMF Files (Type(s)/No)	No	No	
SP-MIDI compatible? (Yes/No)	No	No	

MIDI Implementation Chart v 2.0 (Page 2 of 3)

Manufacturer: RJM Music Technology, Inc. Model: MasterMind GT Version: 1 Date: September 11, 2018

Control #	Function	Transmitted (Y/N)	Recognized (Y/N)	Remarks
0	Bank Select (MSB)	Y	Y	
1	Modulation Wheel (MSB)	Y	N	
2	Breath Controller (MSB)	Y	N	
3		Y	N	
4	Foot Controller (MSB)	Y	N	
5	Portamento Time (MSB)	Y	N	
6	Data Entry (MSB)	Y	N	
7	Channel Volume (MSB)	Y	N	Exp pedal 1 default
8	Balance (MSB)	Y	N	Exp pedal 2 default
9		Y	N	Exp pedal 3 default
10	Pan (MSB)	Y	N	Exp pedal 4 default
11	Expression (MSB)	Y	N	
12	Effect Control 1 (MSB)	Y	N	
13	Effect Control 2 (MSB)	Y	N	
14		Y	N	
15		Y	N	
16	General Purpose Controller 1 (MSB)	Y	N	
17	General Purpose Controller 2 (MSB)	Y	N	
18	General Purpose Controller 3 (MSB)	Y	N	
19	General Purpose Controller 4 (MSB)	Y	N	
20		Y	N	
21		Y	N	
22		Y	N	
23		Y	N	
24		Y	N	
25		Y	N	
26		Y	N	
27		Y	N	
28		Y	N	
29		Y	N	
30		Y	N	
31		Y	N	
32	Bank Select (LSB)	Y	Y	
33	Modulation Wheel (LSB)	Y	N	
34	Breath Controller (LSB)	Y	N	
35		Y	N	
36	Foot Controller (LSB)	Y	N	
37	Portamento Time (LSB)	Y	N	
38	Data Entry (LSB)	Y	N	
39	Channel Volume (LSB)	Y	N	
40	Balance (LSB)	Y	N	
41		Y	N	
42	Pan (LSB)	Y	N	
43	Expression (LSB)	Y	N	
44	Effect Control 1 (LSB)	Y	N	
45	Effect Control 2 (LSB)	Y	N	
46		Y	N	
47		Y	N	
48	General Purpose Controller 1 (LSB)	Y	N	
49	General Purpose Controller 2 (LSB)	Y	N	
50	General Purpose Controller 3 (LSB)	Y	N	
51	General Purpose Controller 4 (LSB)	Y	N	
52		Y	N	
53		Y	N	
54		Y	N	
55		Y	N	
56		Y	N	
57		Y	N	
58		Y	N	
59		Y	N	
60		Y	N	
61		Y	N	
62		Y	N	
63		Y	N	

Control #	Function	Transmitted (Y/N)	Recognized (Y/N)	Remarks
64	Sustain Pedal	Y	N	
65	Portamento On/Off	Y	N	
66	Sostenuto	Y	N	
67	Soft Pedal	Y	N	
68	Legato Footswitch	Y	N	
69	Hold 2	Y	N	
70	Sound Controller 1 (default: Sound Variation)	Y	N	
71	Sound Controller 2 (default: Timbre / Harmonic Quality)	Y	N	
72	Sound Controller 3 (default: Release Time)	Y	N	
73	Sound Controller 4 (default: Attack Time)	Y	N	
74	Sound Controller 5 (default: Brightness)	Y	N	
75	Sound Controller 6 (GM2 default: Decay Time)	Y	N	
76	Sound Controller 7 (GM2 default: Vibrato Rate)	Y	N	
77	Sound Controller 8 (GM2 default: Vibrato Depth)	Y	N	
78	Sound Controller 9 (GM2 default: Vibrato Delay)	Y	N	
79	Sound Controller 10 (GM2 default: Undefined)	Y	N	
80	General Purpose Controller 5	Y	N	
81	General Purpose Controller 6	Y	N	
82	General Purpose Controller 7	Y	N	
83	General Purpose Controller 8	Y	N	
84	Portamento Control	Y	N	
85		Y	N	
86		Y	N	
87		Y	N	
88		Y	N	
89		Y	N	
90		Y	N	
91	Effects 1 Depth (default: Reverb Send)	Y	N	
92	Effects 2 Depth (default: Tremolo Depth)	Y	N	
93	Effects 3 Depth (default: Chorus Send)	Y	N	
94	Effects 4 Depth (default: Celeste [Detune] Depth)	Y	N	
95	Effects 5 Depth (default: Phaser Depth)	Y	N	
96	Data Increment	Y	N	
97	Data Decrement	Y	N	
98	Non-Registered Parameter Number (LSB)	Y	N	
99	Non-Registered Parameter Number(MSB)	Y	N	
100	Registered Parameter Number (LSB)	Y	N	
101	Registered Parameter Number(MSB)	Y	N	
102		Y	N	
103		Y	N	
104		Y	N	
105		Y	N	
106		Y	N	
107		Y	N	
108		Y	N	
109		Y	N	
110		Y	N	
111		Y	N	
112		Y	N	
113		Y	N	
114		Y	N	
115		Y	N	
116		Y	N	
117		Y	N	
118		Y	N	
119		Y	N	
120	All Sound Off	Y	N	
121	Reset All Controllers	Y	N	
122	Local Control On/Off	Y	N	
123	All Notes Off	Y	N	
124	Omni Mode Off	Y	N	
125	Omni Mode On	Y	N	
126	Poly Mode Off	Y	N	
127	Poly Mode On	Y	N	

